























































































































































<b>SUPPORT BASE</b>		Page 06-11
<b>SPACER AND GUIDE RAIL CLAMP</b>		Page 12-35
<b>KNOB FOR BRACKET AND HANDLE</b>		Page 36-41
<b>HINGES</b>		Page 42
<b>COMP. FOR CHAINS TABLETOP</b>		Page 43-56
<b>CONVEYOR BUSHINGS AND EXPANSION PLUGS</b>		Page 57-59
<b>COMPONENTS FOR DRIVE AND IDLER ROLLER</b>		Page 60-62
<b>TRANSFER PLATES AND CONVOYER GUIDES</b>		Page 63-79
<b>REDUCERS FOR RACKS</b>		Page 80-81
<b>POLYAMIDE SUPPORTS</b>		Page 82-98
<b>FIXED, ARTICULATED AND ADJUSTABLE FEET (polyamide, nickel and inox)</b>		Page 99-119
<b>THREADED BUSHINGS FOR TUBES Rectangular, Round and Square</b>		Page 120-126

CONVEYOR COMPONENTS

						
D00/DX00 pag. 006	D01/DX01 pag. 006	D02/DX02 pag. 007	D03/DX03 pag. 007	D12/DX12 pag. 008	D08/DX08 pag. 008	D11/DX11 pag. 009
						
D07/DX07 pag. 009	D10/DX10 pag. 010	D35 pag. 010	D36 pag. 011	D13 pag. 012	D14 pag. 012	D79 pag. 013
						
D15 pag. 013	D80 pag. 014	D43 pag. 014	D81 pag. 015	D16/DX16 pag. 015	D18/DX18 pag. 016	D44/DX44 pag. 016
						
D17 pag. 017	D19 pag. 017	D55 pag. 018	D09 pag. 018	D20 pag. 019	D42 pag. 019	D22 pag. 020
						
D21 pag. 020	D66 pag. 021	D23/DX23 pag. 021	D24 pag. 022	D25 pag. 022	D56 pag. 022	D89 pag. 023
						
D29 pag. 023	D30 pag. 024	D31 pag. 024	D32 pag. 025	T46 pag. 025	T47 pag. 026	D91 pag. 026
						
T48 pag. 027	T49 pag. 027	D90 pag. 028	D04 pag. 028	D05 pag. 029	T01 pag. 029	T16 pag. 030
						
T02 pag. 030	T06 pag. 031	T38 pag. 031	T24 pag. 032	D37 pag. 032	D39 pag. 033	D40 pag. 033
						
D41 pag. 034	D97 pag. 035	T12 pag. 035	D26 pag. 036	D27 pag. 036	D28 pag. 036	D46 pag. 037
						
D47 pag. 037	D48 pag. 037	T13 pag. 038	T14 pag. 038	T15 pag. 038	T34 pag. 039	T37 pag. 039
						
T38 pag. 039	T03 pag. 040	T04 pag. 040	T05 pag. 040	T50 pag. 041	T32 pag. 041	D94 pag. 041

 D33 pag. 042	 D34 pag. 042	 D68 pag. 043	 D69 pag. 043	 T11 pag. 044	 D85 pag. 044	 T10 pag. 045
 D88 pag. 046	 D50 pag. 047	 D51 pag. 047	 D52 pag. 048	 D96 pag. 048	 D53 pag. 049	 D70 pag. 049
 D71 pag. 050	 D3 pag. 050	 D74 pag. 051	 D87 pag. 051	 D86 pag. 052	 D75 pag. 052	 D72 pag. 053
 D67 pag. 053	 D49 pag. 054	 D45 pag. 054	 D93 pag. 055	 D76 pag. 055	 D54 pag. 056	 D82 pag. 056
 T36 pag. 057	 T35 pag. 057	 D83 pag. 058	 T33 pag. 059	 T00 pag. 060	 D65 pag. 060	 D63 pag. 061
 T17 pag. 061	 D64 pag. 062	 D57 pag. 063	 D58 pag. 063	 D59 pag. 063	 D60 pag. 064	 D61 pag. 064
 D62 pag. 064	 T06 pag. 065	 T07 pag. 065	 T08 pag. 066	 T19 pag. 066	 T25 pag. 067	 T26 pag. 067
 T27 pag. 068	 T28 pag. 068	 T55 pag. 069	 T56 pag. 069	 T57 pag. 070	 T58 pag. 070	 T20,21,22,23 pag. 071
 T40 pag. 071	 T41 pag. 072	 T42 pag. 072	 T43 pag. 073	 T29 pag. 073	 T53 pag. 073	 T54 pag. 074
 T18 pag. 074	 T39 pag. 075	 T44 pag. 075	 T45 pag. 076	 T30/TX30 pag. 076	 T59 pag. 077	 T60 pag. 078
 T52 pag. 079	 T31 pag. 080	 D99 pag. 081				

## Support base (tripode) Type: D00 e DX00

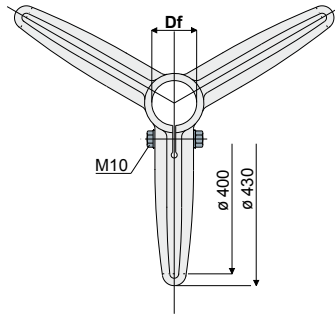
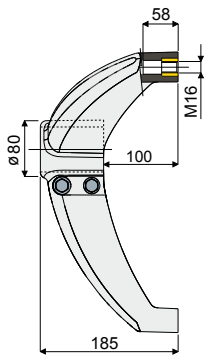

Df Bore for tubes of		Zinc plated bolts and nuts		Stainless steel AISI 304 bolts and nuts		Tube unthreading load (N)	Max static load allowed (N)
(mm)	(Inches)	Type	Code	Type	Code		
60,3	2"	D00A	CP000001	DX00A	CP000006	9600	15800
50,8	-	D00B	CP000002	DX00B	CP000007		
48,3	1"1/2	D00C	CP000003	DX00C	CP000008		
42,4	1"1/4	D00D	CP000004	DX00D	CP000009		
45x45	tubo quadro	D00E	CP000005	DX00E	CP000010		

## Support base (bipode at 120°) Type: D01 e DX01

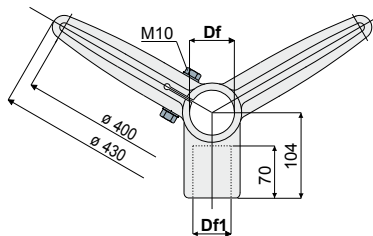
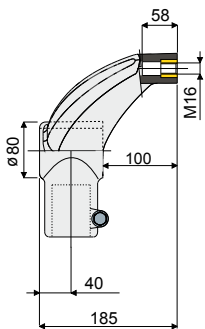

Df Bore for tubes of		Df1 Bore for tubes of		Zinc plated bolts and nuts		Stainless steel AISI 304 bolts and nuts		Tube unthreading load (N)	Max static load allowed (N)
(mm)	(Inches)	(mm)	(Inches)	Type	Code	Type	Code		
60,3	2"	48,3	1"1/2	D01A	CP000011	DX01A	CP000018	9600	15800
60,3	2"	42,4	1"1/4	D01B	CP000012	DX01B	CP000019		
50,8	-	48,3	-	D01C	CP000013	DX01C	CP000020		
50,8	-	42,4	-	D01D	CP000014	DX01D	CP000021		
48,3	1"1/2	48,3	1"1/2	D01E	CP000015	DX01E	CP000022		
48,3	1"1/2	42,4	1"1/4	D01F	CP000016	DX01F	CP000023		
42,4	1"1/4	42,4	1"1/4	D01G	CP000017	DX01G	CP000024		

**MATERIALS:** Base made of reinforced polyamide black colour; threaded bushing made of brass; fixing bolts and nuts made of stainless steel AISI 304 or zinc plated steel.

**FEATURES:** Max tightening torque 3,6 Kg-m.

**BOX QUANTITY:** 8 pieces.

**ON REQUEST:**

- Bases: In reinforced polypropylene, other colours.
- Box Quantity: According to your request.
- Assembling of: Bolts and nuts.

Support base (bipode at 180°) Type: D02 e DX02

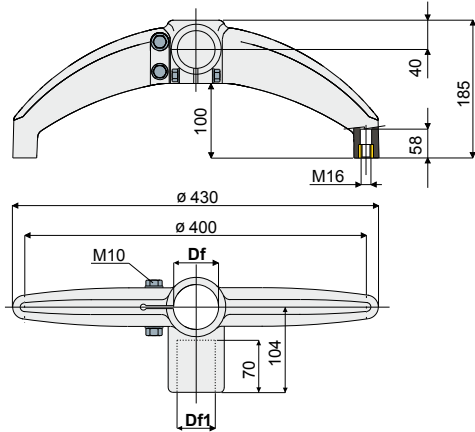

Df		Df1		Zinc plated bolts and nuts		Stainless steel AISI 304 bolts and nuts		Tube unthreading load (N)	Max static load allowed (N)
Bore for tubes of (mm)	(Inches)	Bore for tubes of (mm)	(Inches)	Type	Code	Type	Code		
60,3	2"	48,3	1"1/2	D02A	CP000025	DX02A	CP000032	9600	15800
60,3	2"	42,4	1"1/4	D02B	CP000026	DX02B	CP000033		
50,8	-	48,3	-	D02C	CP000027	DX02C	CP000034		
50,8	-	42,4	-	D02D	CP000028	DX02D	CP000035		
48,3	1"1/2	48,3	1"1/2	D02E	CP000029	DX02E	CP000036		
48,3	1"1/2	42,4	1"1/4	D02F	CP000030	DX02F	CP000037		
42,4	1"1/4	42,4	1"1/4	D02G	CP000031	DX02G	CP000038		

Support base (bipode at 180°) Type: D03 e DX03

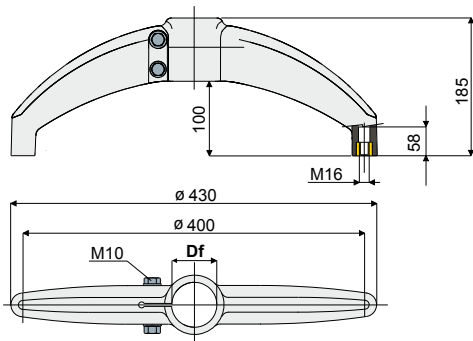

Df		Zinc plated bolts and nuts		Stainless steel AISI 304 bolts and nuts		Tube unthreading load (N)	Max static load allowed (N)
Bore for tubes of (mm)	(Inches)	Type	Code	Type	Code		
60,3	2"	D03A	CP000039	DX03A	CP000043	9600	15800
50,8	-	D03B	CP000040	DX03B	CP000044		
48,3	1"1/2	D03C	CP000041	DX03C	CP000045		
42,4	1"1/4	D03D	CP000042	DX03D	CP000046		

MATERIALS: Base made of reinforced polyamide black colour; threaded bushing made of brass; fixing bolts and nuts made of stainless steel AISI 304 or zinc plated steel.

FEATURES: Max tightening torque 3,6 Kg-m.

BOX QUANTITY: 8 pieces.

ON REQUEST:

- Bases: In reinforced polypropylene, other colours.
- Box Quantity: According to your request.
- Assembling of: Bolts and nuts.

## Bearing head Type: D12 e DX12

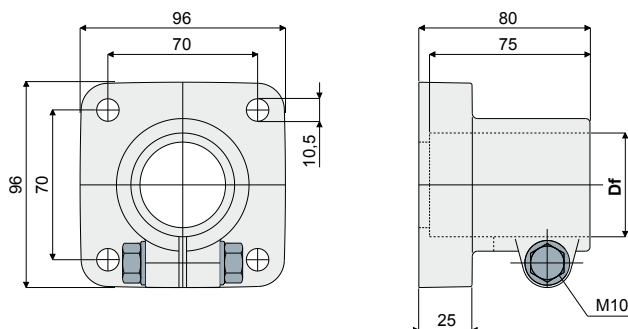

Df Bore for tubes of		Zinc plated bolts and nuts		Stainless steel AISI 304 bolts and nuts	
(mm)	(Inches)	Type	Code	Type	Code
48,3	1"1/2	D12A	CP000047	DX12A	CP000049
50,8	-	D12B	CP000048	DX12B	CP000050

## Bearing head Type: D08 e DX08

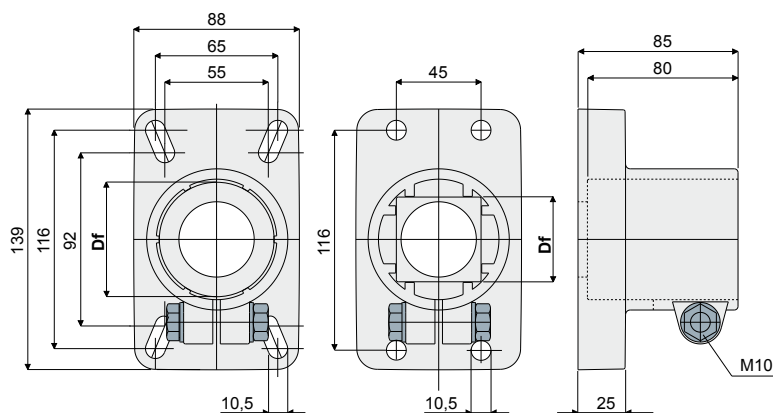

Df Bore for tubes of		Zinc plated bolts and nuts		Stainless steel AISI 304 bolts and nuts	
(mm)	(Inches)	Type	Code	Type	Code
60,3	2"	D08A	CP000051	DX08A	CP000056
50,8	-	D08B	CP000052	DX08B	CP000057
48,3	1"1/2	D08C	CP000053	DX08C	CP000058
42,4	1"1/4	D08D	CP000054	DX08D	CP000059
45x45	tubo quadro	D08E	CP000055	DX08E	CP000060

**MATÉRIAUX:** Tête en polyamide renforcé couleur noir; boulons de serrage en acier inox AISI 304 ou acier zingué.

**CARACTÉRISTIQUES:** Couple maximal de serrage 3,6 Kg·m.

**CONDITIONNEMENT:** 8 pièces.

**SUR DEMANDE:**

- Têtes: En polypropylène renforcé, dans différentes couleurs.
- Conditionnement: Hors standard.
- Assemblage de: vis, écrous et rondelles.

Side mounting top bracket Type: D11 e DX11

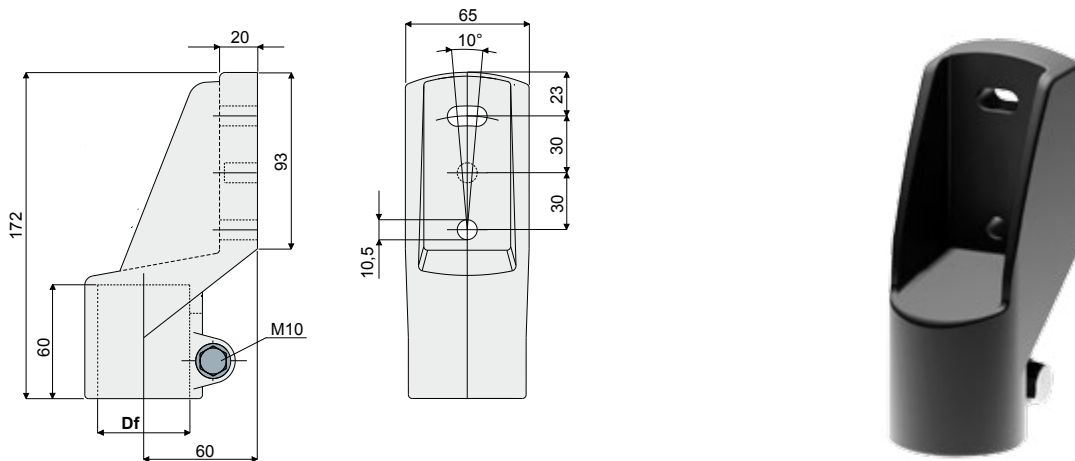

Df Bore for tubes of		Zinc plated bolts and nuts		Stainless steel AISI 304 bolts and nuts	
(mm)	(Inches)	Type	Code	Type	Code
48,3	1"1/2	D11	CP000061	DX11	CP000062

Side mounting top bracket Type: D07 e DX07

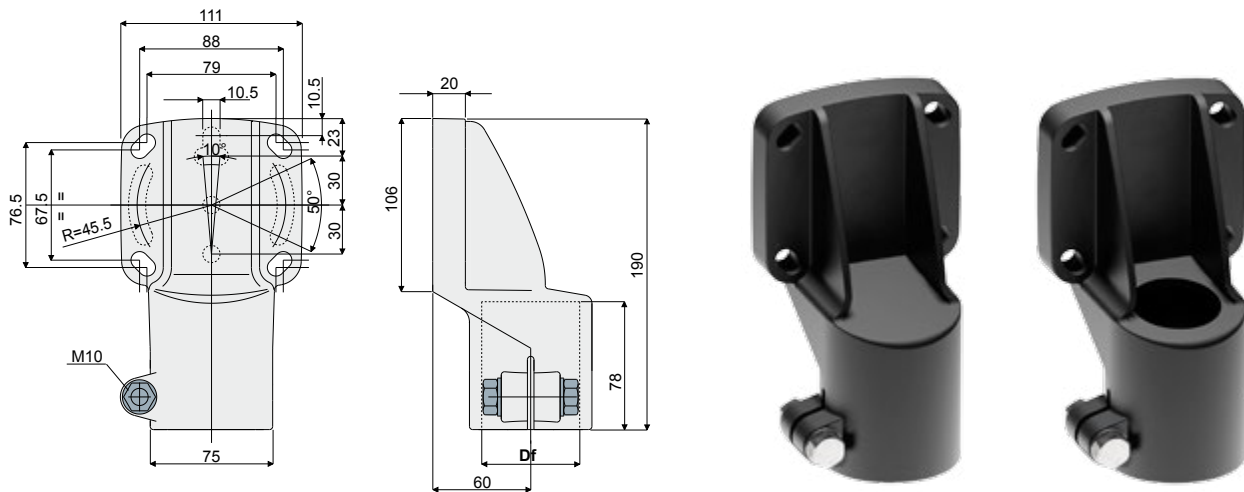

Df Bore for tubes of		Zinc plated bolts and nuts		Stainless steel AISI 304 bolts and nuts	
(mm)	(Inches)	Type	Code	Type	Code
60,3	2"	D07A	CP000063	DX07A	CP000069
50,8	-	D07B	CP000064	DX07B	CP000070
48,3	1"1/2	D07C	CP000065	DX07C	CP000071
42,4	1"1/4	D07D	CP000066	DX07D	CP000072
45x45	square tube	D07E	CP000067	DX07E	CP000073
48,3	trou	D07F	CP000068	DX07T	CP000074

**MATERIALS:** Top bracket made out of reinforced polyamide black colour; bolts and nuts made out of stainless steel AISI 304 or zinc plated steel.

**FEATURES:** Max tightening torque 3,6 Kg-m.

**BOX QUANTITY:** 8 pieces.

**ON REQUEST:**

- Top brackets: In reinforced polypropylene, other colours.
- Box Quantity: According to your request.
- Assembling of: Bolts and nuts.gg

Connection joint Type: D10 e DX10

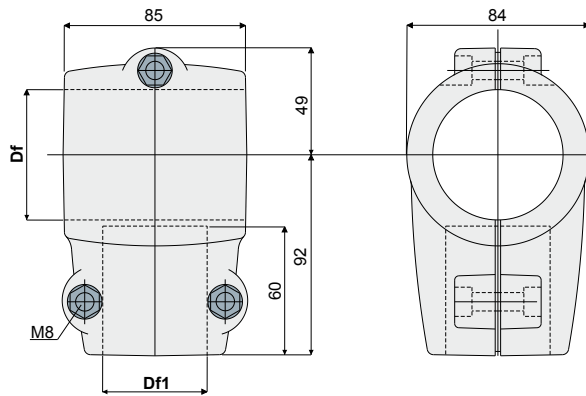

Df		Df1		Zinc plated bolts and nuts		Stainless steel AISI 304 bolts and nuts	
Bore for tubes of		Bore for tubes of		Type	Code	Type	Code
(mm)	(Inches)	(mm)	(Inches)				
60,3	2"	48,3	1"1/2	D10A	CP000075	DX10A	CP000075
60,3	2"	42,4	1"1/4	D10B	CP000076	DX10B	CP000076
48,3	1"1/2	48,3	1"1/2	D10C	CP000077	DX10C	CP000077
48,3	1"1/2	42,4	1"1/4	D10D	CP000078	DX10D	CP000078
42,4	1"1/4	42,4	1"1/4	D10E	CP000079	DX10E	CP000079

MATERIALS: Joint made of reinforced polyamide black colour; bolts and nuts made of stainless steel AISI 304 or zinc plated steel.

FEATURES: Max tightening torque 2 Kg-m.

BOX QUANTITY: 8 pieces.

ON REQUEST:

- Joints: In reinforced polypropylene, other colours.
- Box Quantity: According to your request.
- Assembling of: Bolts and nuts.

Mounting plate (for drip tray support) Type: D35

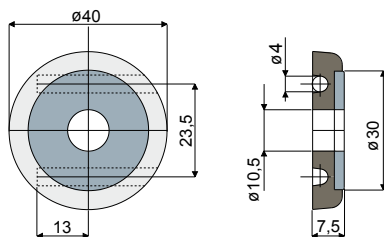

Type	Code
D35	CP000085

MATERIALS: Plate made of reinforced polyamide black colour; washer made of stainless steel AISI 304.

FEATURES: For application on conveyor side to fasten drip tray support.

BOX QUANTITY: 24 pieces.

ON REQUEST:

- Box Quantity: According to your request.



Drip tray support Type: D36

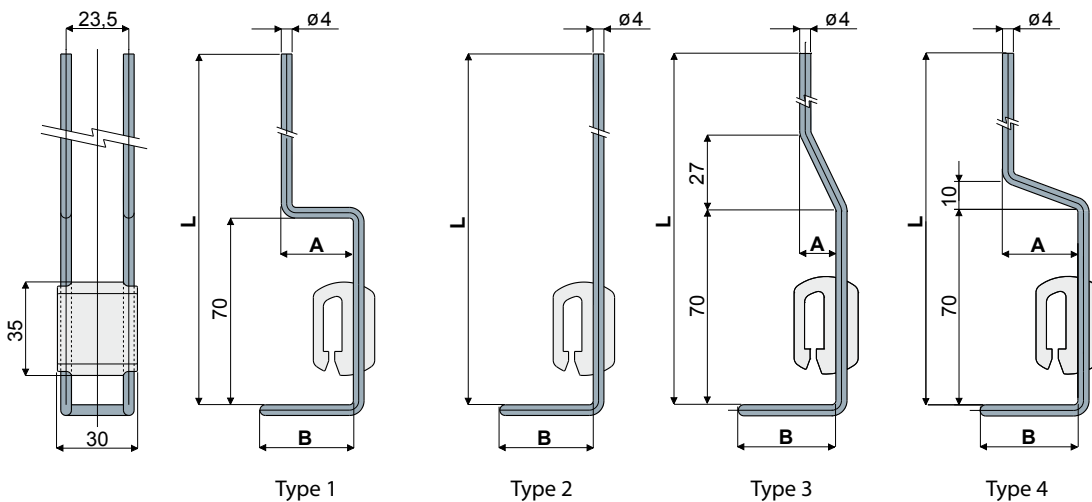
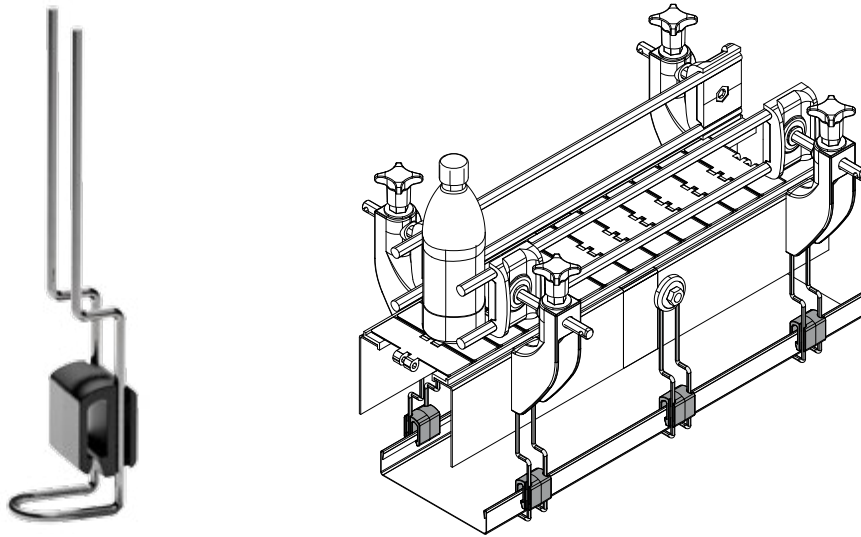

L		B		A		Type 1	
(mm)	(mm)	(mm)	(mm)	(mm)	Type	Code	
180	35	27	D36A	CP000086			
180	35	17	D36B	CP000087			
230	35	27	D36C	CP000088			

L		B		Type 2	
(mm)	(mm)	(mm)	Type	Code	
200	35	D36D	CP000089		
246	35	D36E	CP000090		

L		B		A		Type 3	
(mm)	(mm)	(mm)	Type	Code			
250	35	13	D36F	CP000091			

L		B		A		Type 4	
(mm)	(mm)	(mm)	Type	Code			
280	35	27	D36G	CP000092			

**MATERIALS:** Support elements made of stainless steel AISI 304; body of coupling made of reinforced polyamide black colour.

**FEATURES:** To be used to support drip trays.

**BOX QUANTITY:** 24 pieces.

**ON REQUEST:**

- Drip tray supports: Supplied in different shapes and sizes.
- Box Quantity: According to your request.

Guide rail bracket Type: D13

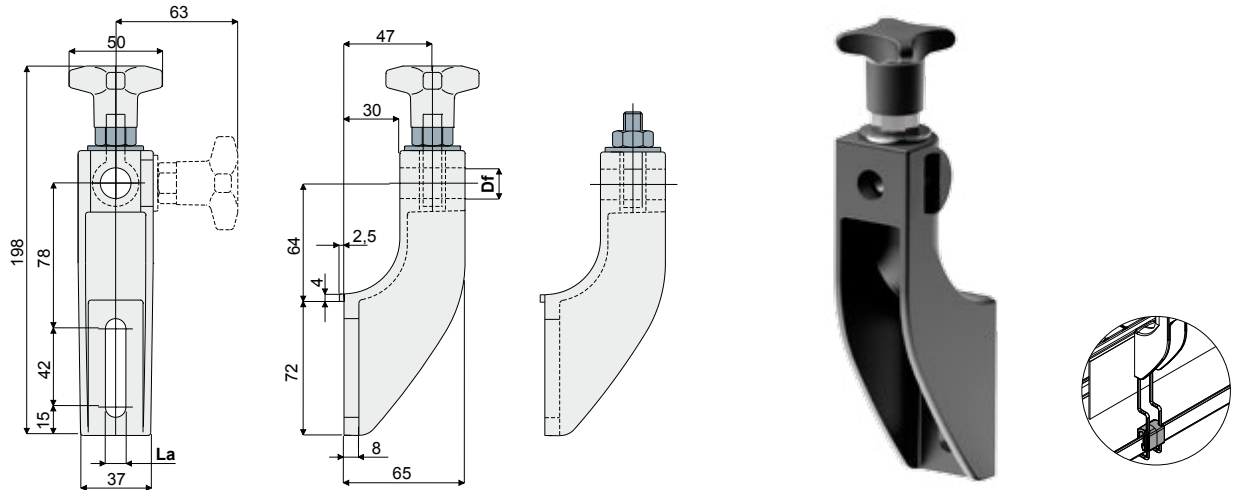

La (9 mm slot)				
Df Bore for pin of (mm)	With knob		With nut	
	Type	Code	Type	Code
12	D13A	CP000093	D13D	CP000096
14	D13B	CP000094	D13E	CP000097
16	D13C	CP000095	D13F	CP000098

La (11 mm slot)				
Df Bore for pin of (mm)	With knob		With nut	
	Type	Code	Type	Code
12	D13G	CP000099	D13L	CP000102
14	D13H	CP000100	D13M	CP000103
16	D13I	CP000101	D13N	CP000104

Guide rail bracket (with adjustable head) Type: D14

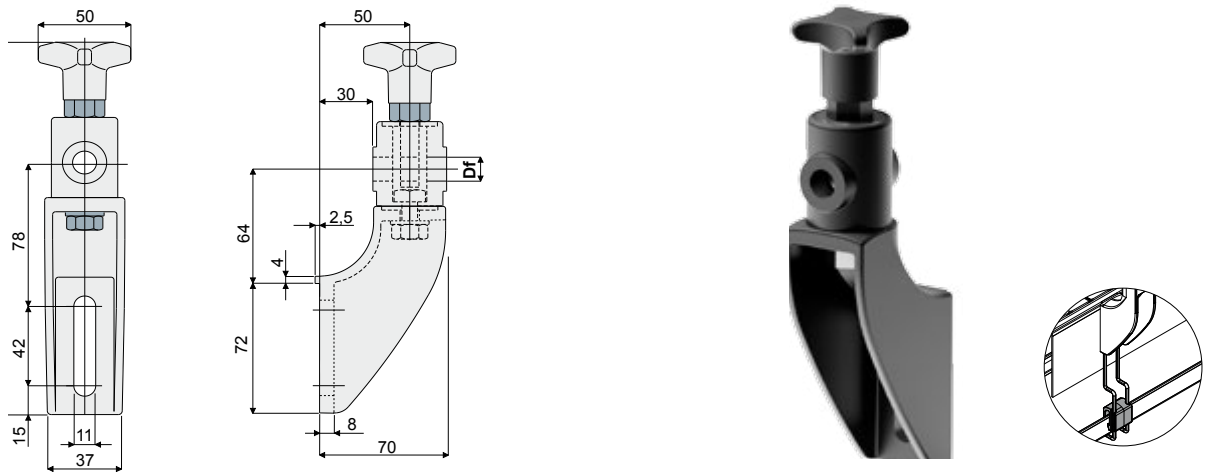

Df Bore for pin of (mm)	Type	Code
12	D14A	CP000105
14	D14B	CP000106
16	D14C	CP000107

MATERIALS: Bracket and knob made of reinforced polyamide black colour; hexagonal insert made of nickel plated brass; eyebolt, nut and washer made of stainless steel AISI 304.

FEATURES: Max tightening torque 4 Kg-m.

BOX QUANTITY: 24 pieces.

ON REQUEST:

- Brackets: In reinforced polypropylene, other colours.
- Box Quantity: According to your request.

Guide rail bracket (with adjustable head) Type: D79

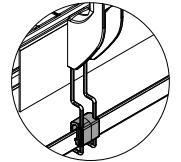
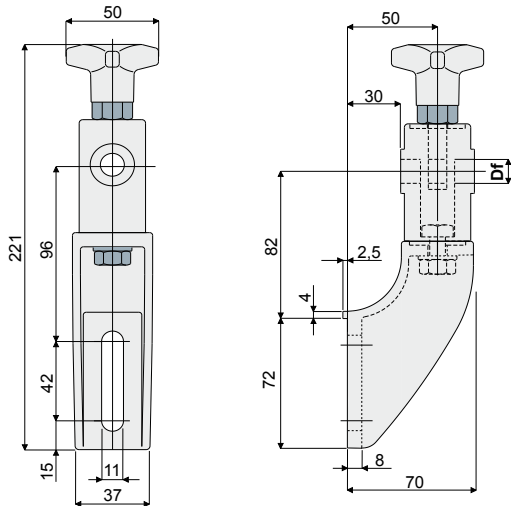

Df Bore for pin of (mm)	Type	Code
12	D79A	CP000108
14	D79B	CP000109
16	D79C	CP000110

Guide rail bracket (with adjustable head) Type: D15

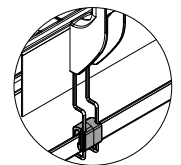
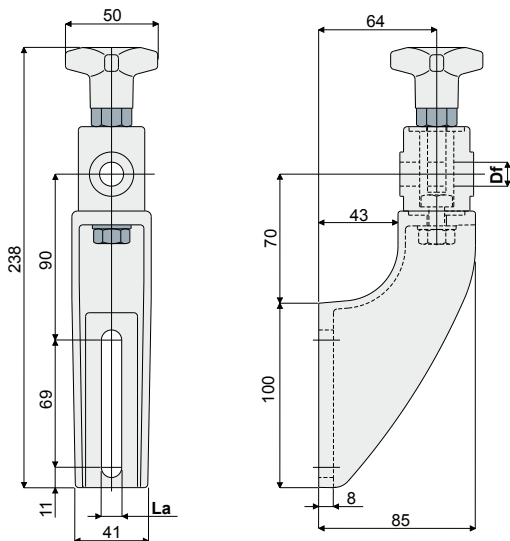

Df Bore for pin of (mm)	La (9 mm slot)		La (11 mm slot)	
	Type	Code	Type	Code
12	D15A	CP000111	D15D	CP000114
14	D15B	CP000112	D15E	CP000115
16	D15C	CP000113	D15F	CP000116

**MATERIALS:** Bracket and knob made of reinforced polyamide black colour; hexagonal insert made of nickel plated brass; eyebolt, nut and washer made of stainless steel AISI 304.

**FEATURES:** Max tightening torque 4 Kg-m.

**BOX QUANTITY:** 24 pieces.

**ON REQUEST:**

- Brackets: In reinforced polypropylene, other colours.
- Box Quantity: According to your request.

Guide rail bracket (with adjustable high type head) Type: D80

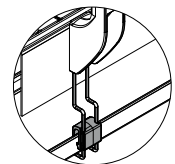
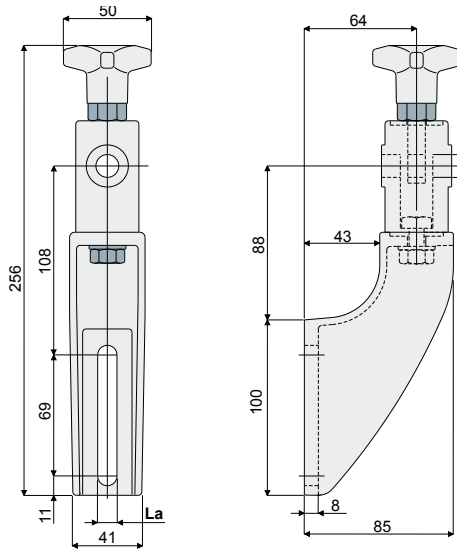

Df Bore for pin of (mm)	La (9 mm slot)		La (11 mm slot)	
	Type	Code	Type	Code
12	D80A	CP000117	D80D	CP000120
14	D80B	CP000118	D80E	CP000121
16	D80C	CP000119	D80F	CP000122

Guide rail bracket (reinforced type with adjustable head) Type: D43

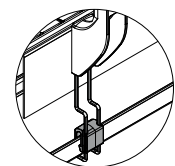
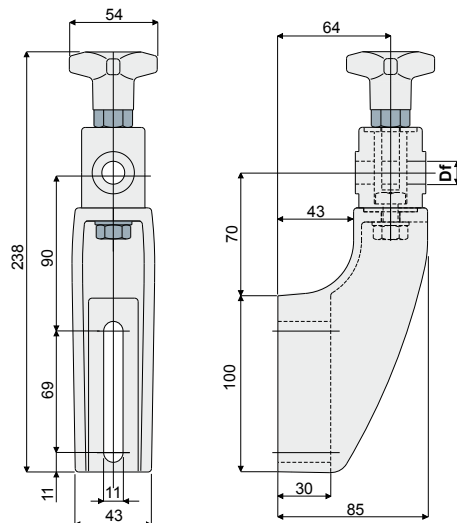

Df Bore for pin of (mm)	Type	Code
12	D43A	CP000123
14	D43B	CP000124
16	D43C	CP000125

MATERIALS: Bracket and knob made of reinforced polyamide black colour; hexagonal insert made of nickel plated brass; eyebolt, screw, nut and washer made of stainless steel AISI 304.

FEATURES: D43 is used for heavy applications, suitable in conveyors with more ways, both in accumulation and curve. D43 and D80 have max tightening torque of 4 Kg-m.

BOX QUANTITY: 24 pieces.

ON REQUEST:

- Brackets: In reinforced polypropylene, other colours.
- Box Quantity: According to your request.

Guide rail bracket (reinforced type with adjustable high type head) Type: D81

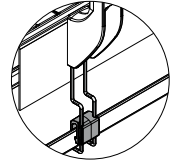
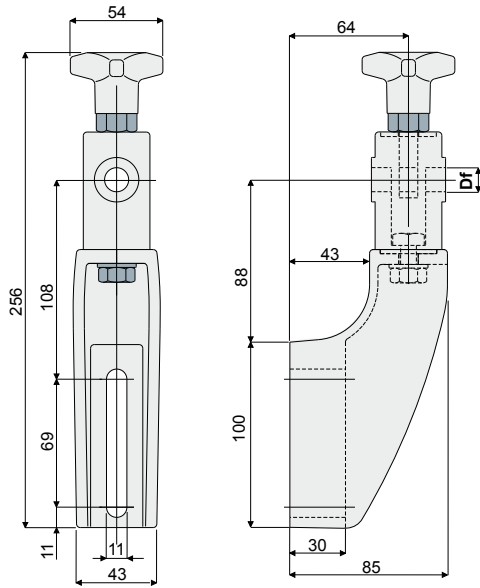

Df Bore for pin of (mm)	Type	Code
12	D81A	CP000126
14	D81B	CP000127
16	D81C	CP000128

Guide rail bracket (with metal adjustable head) Type: D16 e DX16

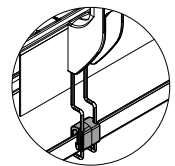
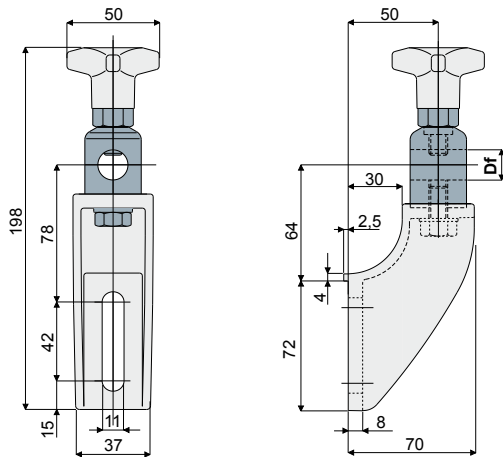

Df Bore for pin of (mm)	Head made out of nickel plated brass		Head made out of stainless steel AISI 304	
	Type	Code	Type	Code
14 - 16	D16	CP000129	DX16	CP000130

**MATERIALS:** Bracket and knob made out of reinforced polyamide black colour; head made out of stainless steel AISI 304 or nickel plated brass; hexagonal insert made out of nickel plated brass; screw and washer made out of stainless steel AISI 304.

**FEATURES:** Possibility to use pins with diameter 14 and 16 mm. Max tightening torque 4 Kg-m.

**BOX QUANTITY:** 24 pieces.

**ON REQUEST:**

- Brackets: In reinforced polypropylene, other colours.
- Box Quantity: According to your request.

Guide rail bracket (with metal adjustable head) Type: D18 e DX18

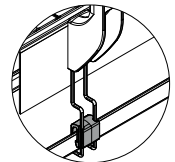
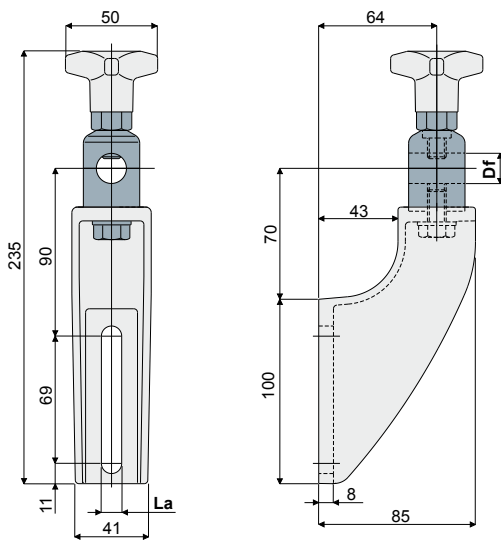

Df Bore for pin of (mm)	La (9 mm slot)		La (11 mm slot)	
	Head made out of nickel plated brass		Head made out of stainless steel AISI 304	
	Type	Code	Type	Code
14 - 16	D18A	CP000131	DX18A	CP000132

Df Bore for pin of (mm)	La (11 mm slot)		La (11 mm slot)	
	Head made out of nickel plated brass		Head made out of stainless steel AISI 304	
	Type	Code	Type	Code
14 - 16	D18B	CP000133	DX18B	CP000134

Guide rail bracket (reinforced type with metal adjustable head) Type: D44

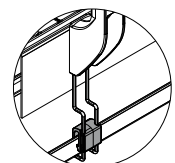
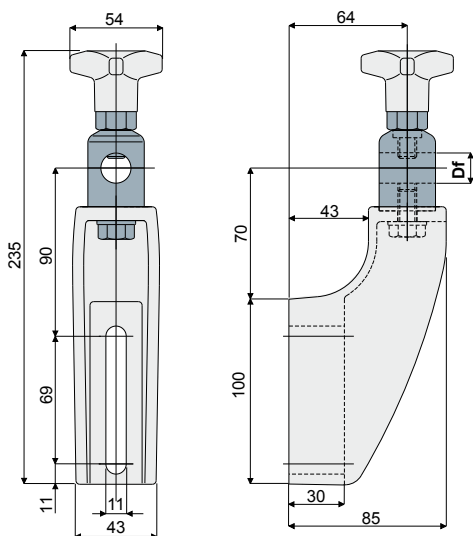

Df Bore for pin of (mm)	Head made out of nickel plated brass		Head made out of stainless steel AISI 304	
	Type	Code	Type	Code
	14 - 16	D44	CP000135	DX44

**MATERIALS:** Bracket and knob made out of reinforced polyamide black colour; head made out of stainless steel AISI 304 or nickel plated brass; hexagonal insert made out of nickel plated brass; screw and washer made out of stainless steel AISI 304.

**FEATURES:** Possibility to use pins with diameter 14 and 16 mm. Max tightening torque 4 Kg·m. D44 is used for heavy applications, suitable in conveyors with more ways, both in accumulation and curve

**BOX QUANTITY:** 24 pieces.

**ON REQUEST:**

- Brackets: In reinforced polypropylene, other colours.
- Box Quantity: According to your request.

Guide rail bracket (with adjustable head) Type: D17

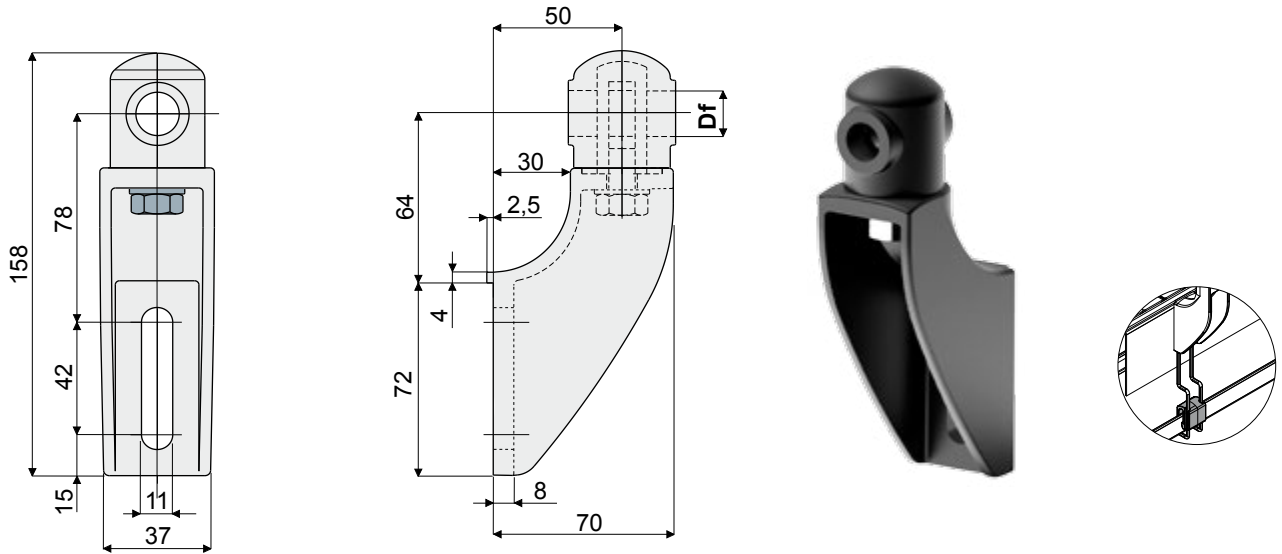

Df Bore for pin of (mm)	Type	Code
12	D17A	CP000137
14	D17B	CP000138
16	D17C	CP000139

Guide rail bracket (with adjustable head) Type: D19

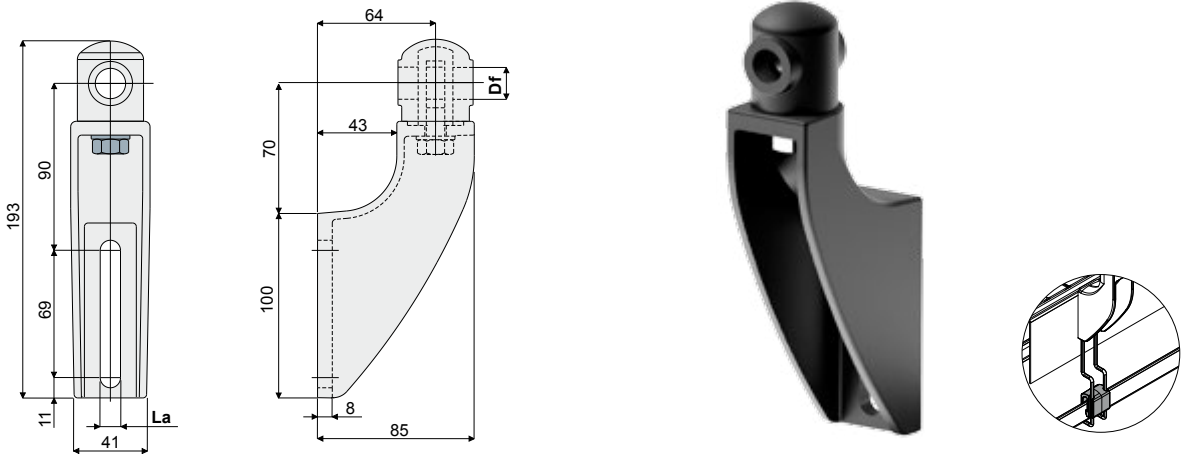

Df Bore for pin of (mm)	La (9 mm slot)		La (11 mm slot)	
	Type	Code	Type	Code
12	D19A	CP000140	D19D	CP000143
14	D19B	CP000141	D19E	CP000144
16	D19C	CP000142	D19F	CP000145

**MATERIALS:** Bracket and head made of reinforced polyamide black colour; eyebolt, nut and washer made of stainless steel AISI 304.

**FEATURES:** Max tightening torque 4 Kg-m.

**BOX QUANTITY:** 24 pieces.

**ON REQUEST:**

- Brackets: In reinforced polypropylene, other colours.
- Box Quantity: According to your request.

Guide rail bracket (reinforced type with adjustable head) Type: D55

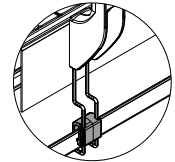
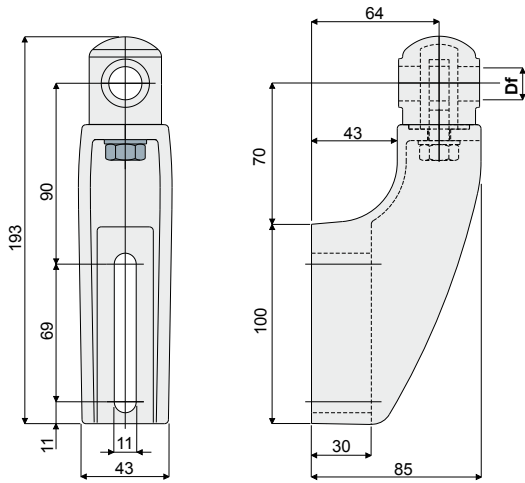

Df Bore for pin of (mm)	Type	Code
12	D55A	CP000146
14	D55B	CP000147
16	D55C	CP000148

Guide rail bracket (with adjustable head) Type: D09

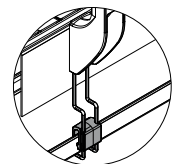
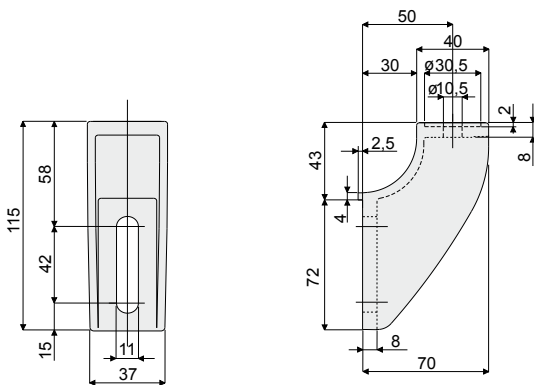

Type	Code
D09	CP000149

MATERIALS: Bracket and head made of reinforced polyamide black colour; eyebolt, nut and washer made of stainless steel AISI 304.

FEATURES: Max tightening torque 4 Kg-m. D55 is used for heavy applications, suitable in conveyors with more ways, both in accumulation and curve. D09 is used with heads D21, D22, D23 and D66.

BOX QUANTITY: 24 pieces.

ON REQUEST:

- Brackets: In reinforced polypropylene, other colours.
- Box Quantity: According to your request.



Guide rail bracket (with adjustable head) Type: D20

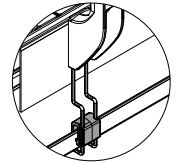
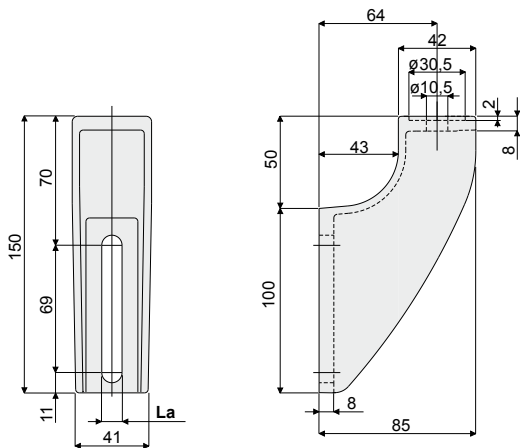

La (9 mm slot)		La (11 mm slot)	
Type	Code	Type	Code
D20A	CP000150	D20B	CP000151

Guide rail bracket (reinforced type with adjustable head) Type: D42

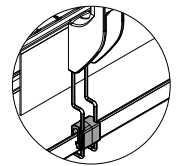
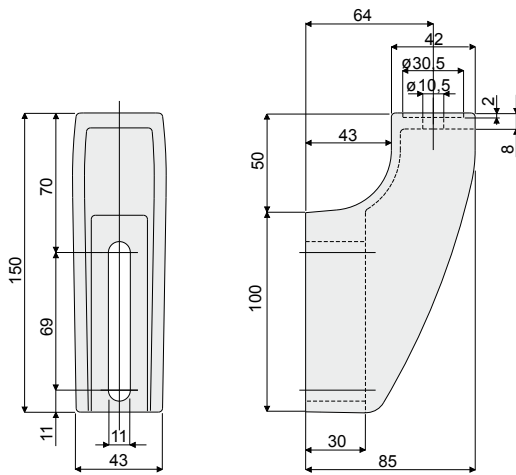

Type	Code
D42	CP000152

**MATERIALS:** Bracket made of reinforced polyamide black colour.

**FEATURES:** Each type are used with heads D21, D22, D23 and D66 for heavy applications.

D42 is suitable in conveyors with more ways, both in accumulation and curve.

**BOX QUANTITY:** 24 pieces.

**ON REQUEST:**

- Brackets: In reinforced polypropylene, other colours.

## Head for bracket Type: D22

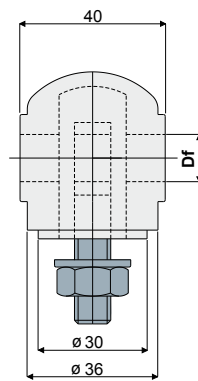
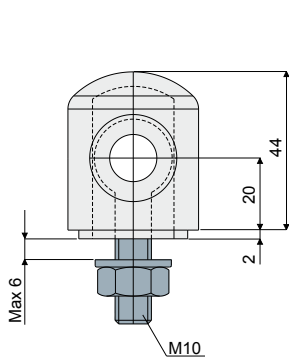

Df Bore for pin of (mm)	Type	Code
12	D22A	CP000153
14	D22B	CP000154
16	D22C	CP000155

## Head for bracket Type: D21

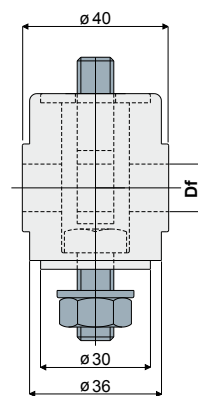
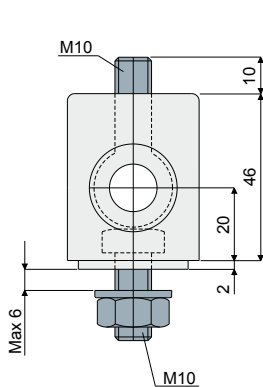

Df Bore for pin of (mm)	Type	Code
12	D21A	CP000156
14	D21B	CP000157
16	D21C	CP000158

**MATERIALS:** Head made of reinforced polyamide black colour; eyebolt, nut and washer made of stainless steel AISI 304.

**FEATURES:** Each parts are used with bracket D09, D20 and D42. Max tightening torque 4 Kg-m.

**BOX QUANTITY:** 24 pieces.

**ON REQUEST:**

- Heads: In reinforced polypropylene, other colours.
- Box Quantity: According to your request.

Head for bracket (high type) Type: D66

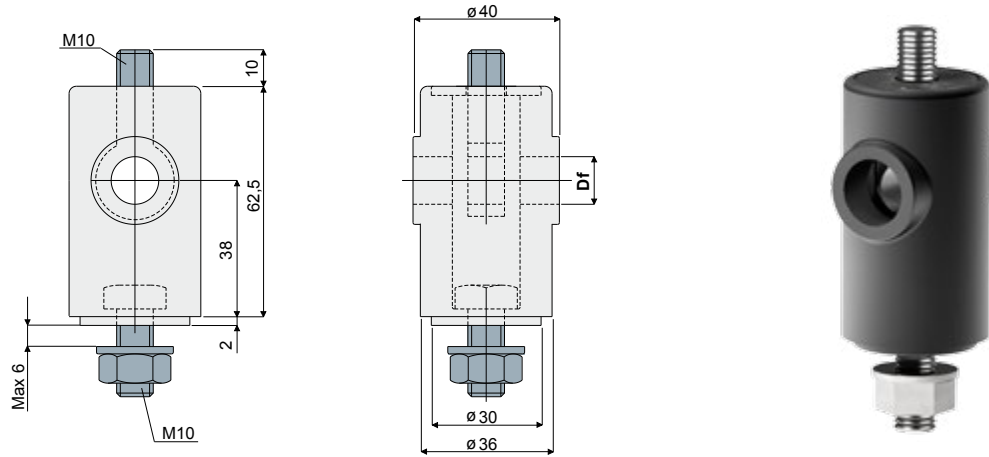

Df Bore for pin of (mm)	Type	Code
12	D66A	CP000159
14	D66B	CP000160
16	D66C	CP000161

Head for bracket (metal) Type: D23 e DX23

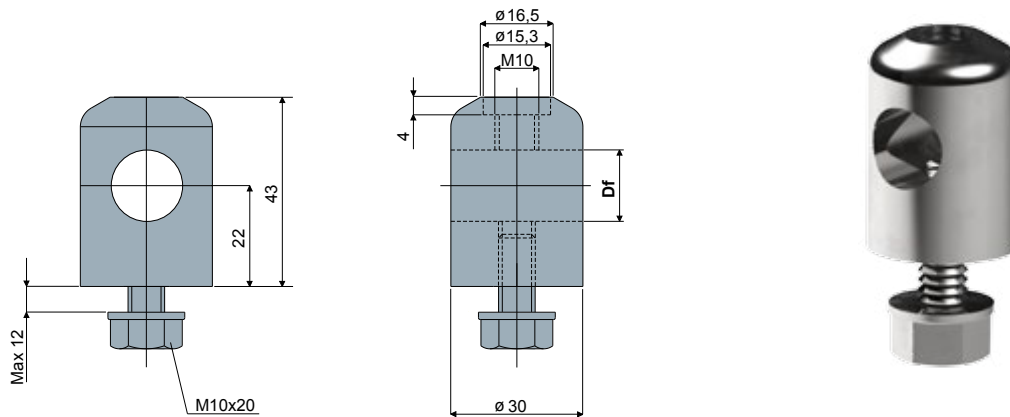

Df Bore for pin of (mm)	Head made out of nickel plated brass		Head made out of stainless steel AISI 304	
	Type	Code	Type	Code
14 - 16	D23	CP000162	DX23	CP000163

**MATERIALS:** Head made of reinforced polyamide black colour; eyebolt, nuts and washer made of stainless steel AISI 304.

**FEATURES:** The two heads are used with bracket D09, D20 and D42. Max tightening torque 4 Kg-m.

**N.B.:** With D23 there is the possibility to use pins with diameter 14 and 16 mm.

**BOX QUANTITY:** 24 pieces.

**ON REQUEST:**

- Heads: Made of reinforced polypropylene, other colours.
- Box Quantity: According to your request.

## Spacer for bracket Type: D24

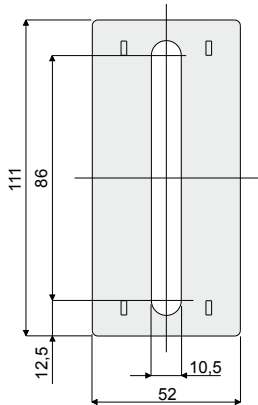

Type	Code
D24	CP000164

## Spacer for bracket Type: D25

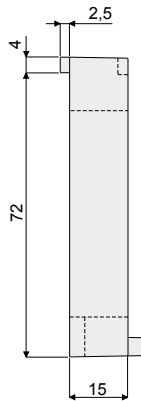
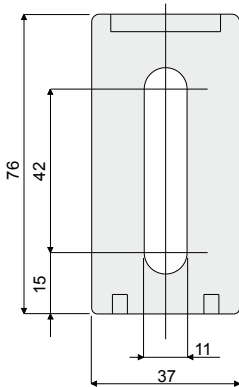

Type	Code
D25	CP000165

## Spacer for heads Type: D56

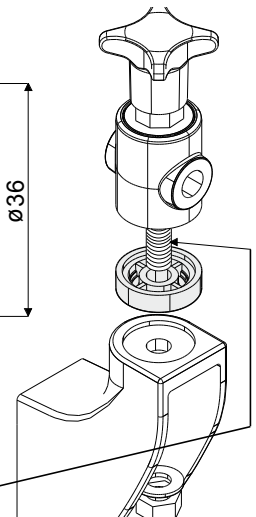
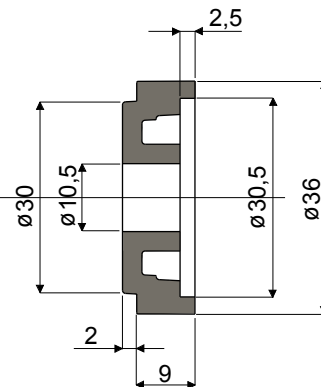
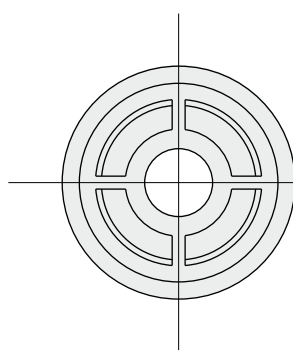

Type	Code
D56	CP000166

N.B.: To use the spacer, it is necessary to change the standard screw with a longer one.

**MATERIALS:** Spacer made of reinforced polyamide black colour.

**FEATURES:** Accessory to be used on brackets D14, D15, D16, D17, D19, D55, D09, D20, D42, D18, D43, D44, D79, D80, D81 to increase heads height. D24 is used with brackets D15, D18, D19, D20, D42, D43, D44, D55, D80, D81 and D25 is used with D13, D14, D16, D17, D09 and D79.

**BOX QUANTITY:** 24 pieces.

**ON REQUEST:**

- Spacers: In reinforced polypropylene, other colours.
- Box Quantity: According to your request.

Guide rail clamp (for rectangular rails) Type: D89

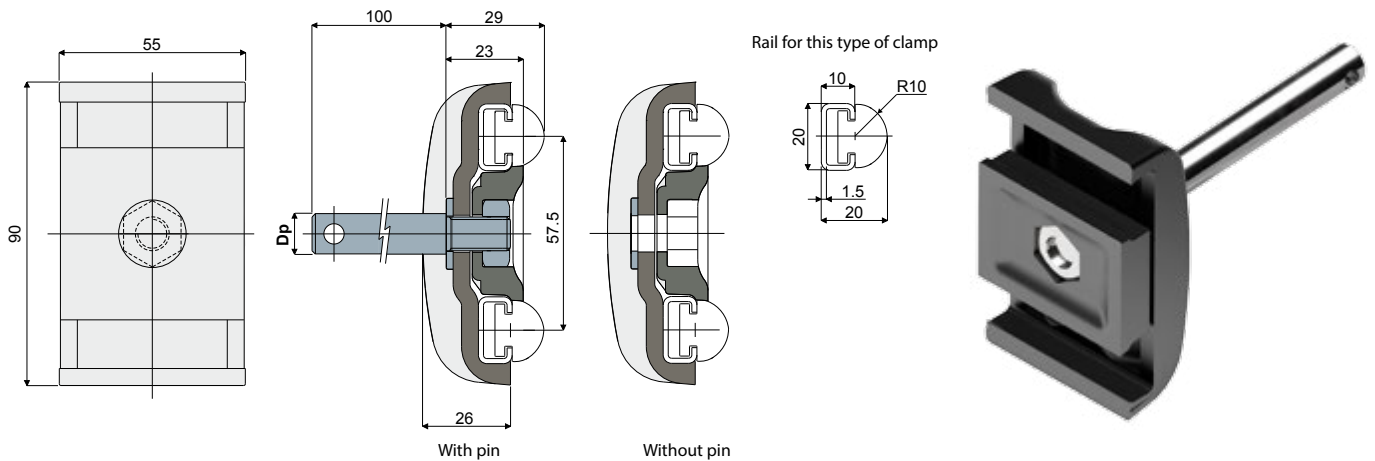

Dp Pin diameter (mm)	With pin		Without pin	
	Type	Code	Type	Code
12	D89A	CP000167		
14	D89B	CP000168	D89D	CP000170
16	D89C	CP000169		

Guide rail clamp (for round rails) Type: D29

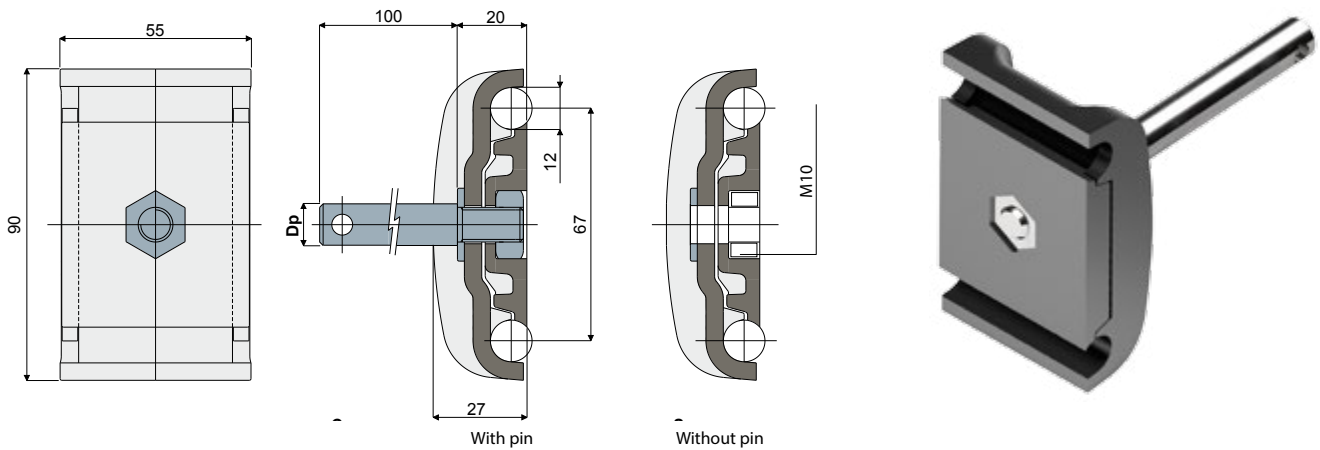

Dp Pin diameter (mm)	With pin		Without pin	
	Type	Code	Type	Code
12	D29A	CP000171		
14	D29B	CP000172	D29D	CP000174
16	D29C	CP000173		

**MATERIALS:** Clamp made of reinforced polyamide black colour; pin, nut and washer made of stainless steel AISI 304.

**FEATURES:** Supplied with or without support pin.

**BOX QUANTITY:** 24 pieces.

**ON REQUEST:**

- Clamps: In reinforced polypropylene, other colours.
- Box Quantity: According to your request.

## Guide rail clamp (for trapezoidal rails) Type: D30

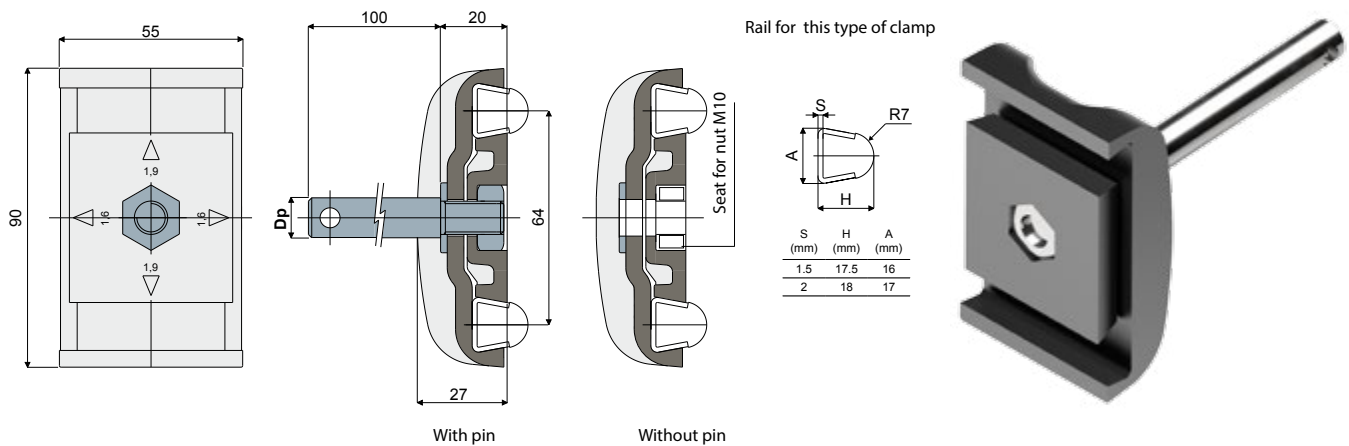

Dp Pin diameter (mm)	With pin		Without pin	
	Type	Code	Type	Code
12	D30A	CP000175		
14	D30B	CP000176	D30D	CP000178
16	D30C	CP000177		

**MATERIALS:** Clamp made of reinforced polyamide black colour; pin, nut and washer made of stainless steel AISI 304.

**FEATURES:** Supplied with or without support pin. This part can be used with rails with thickness of 1,5 and 2 mm, by rotating for 90° the central plate.

**BOX QUANTITY:** 24 pieces.

**ON REQUEST:**

- Clamps: In reinforced polypropylene, other colours.
- Box Quantity: According to your request.

## Guide rail clamp (for round rails) Type: D31

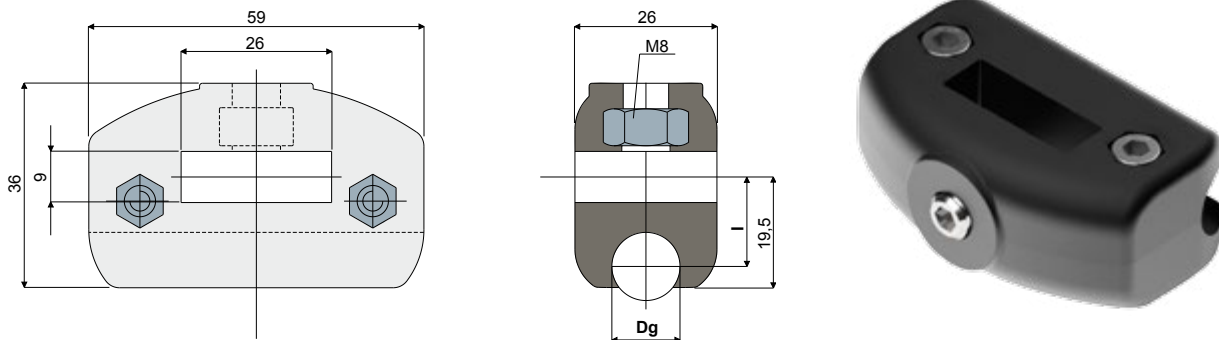

Dg Rail diameter (mm)	l (mm)	Type	Code
8	16	D31A	CP000179
10	15	D31B	CP000180
12	15	D31C	CP000181
14	15	D31D	CP000182

**MATERIALS:** Clamp made of reinforced polyamide black colour; screws and nuts made of stainless steel AISI 304.

**FEATURES:** Supplied assembled. To be used with flat support with sizes 25x8 mm.

**BOX QUANTITY:** 24 pieces.

**ON REQUEST:**

- Clamps: In reinforced polypropylene, other colours.
- Box Quantity: According to your request.

Guide rail clamp (for trapezoidal rails) Type: D32

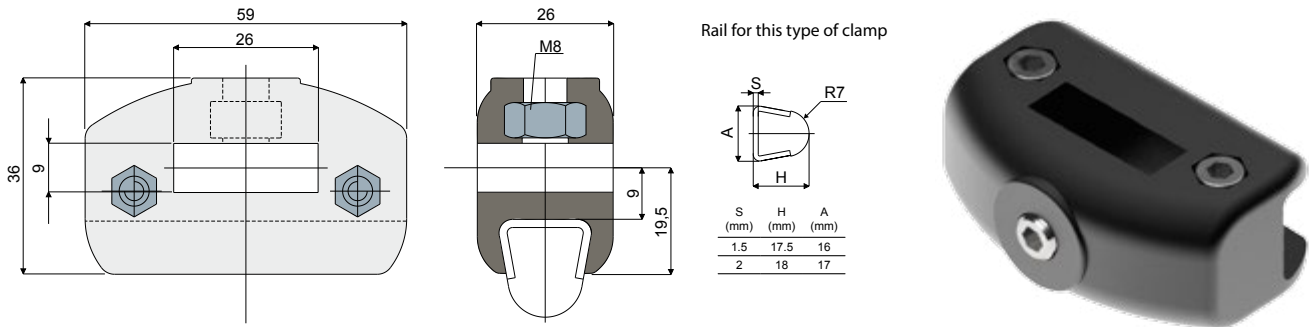

Type	Code
D32	CP000183

**MATERIALS:** Clamp made of reinforced polyamide black colour; screws and nuts made of stainless steel AISI 304.

**FEATURES:** Supplied assembled. To be used with flat support with sizes 25x8 mm. This part can be used with rails with thickness of 1,5 and 2 mm.

**BOX QUANTITY:** 24 pieces.

**ON REQUEST:**

- Clamps: In reinforced polypropylene, other colours.
- Box Quantity: According to your request.

Guide rail clamp (for round rails) Type: T46

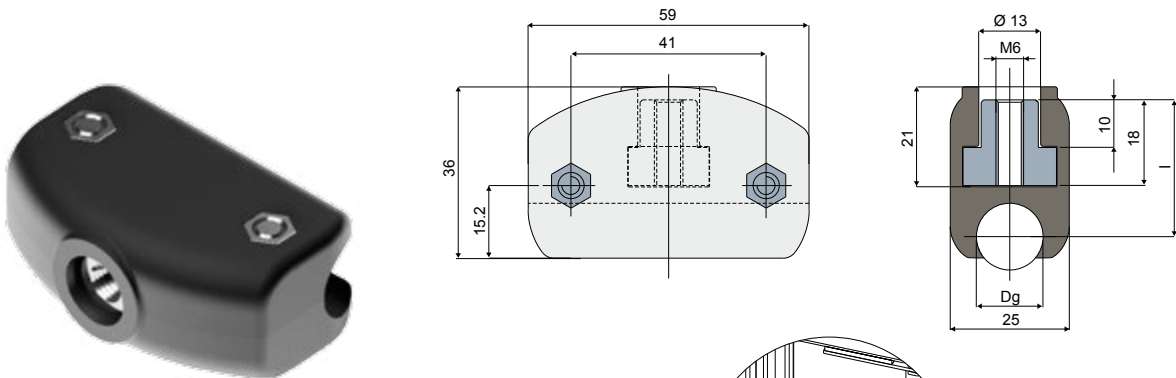

Dg Rail diameter (mm)	l (mm)	Type	Code
8	30	T46A	CP000184
10	29.5	T46B	CP000185
12	29.5	T46C	CP000186
14	28.7	T46D	CP000187

**MATERIALS:** Clamp made of reinforced polyamide black colour; threaded insert in nickel plated brass; bolts and nuts in stainless steel AISI 304.

**FEATURES:** Designed appositely to be assembled directly on the pneumatic cylinder for the rails regulation. Supplied assembled.

**BOX QUANTITY:** 24 pieces.

**ON REQUEST:**

- Clamps: In reinforced polypropylene, other colours.
- Box Quantity: According to your request.

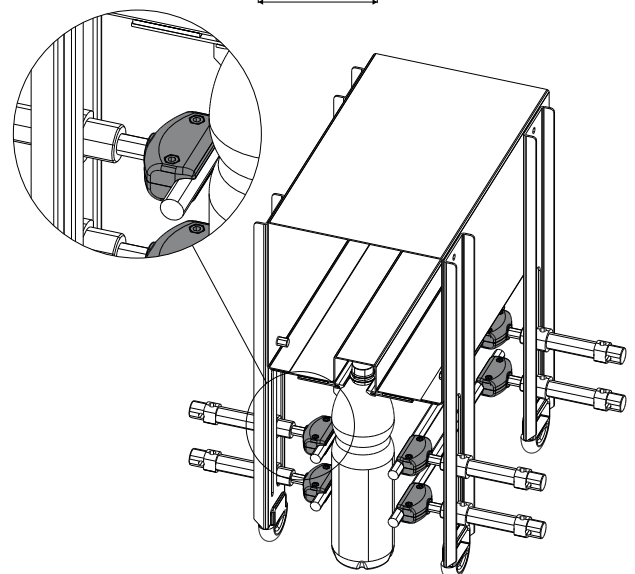

Example of application

Guide rail clamp (for rectangular rails) Type: D91

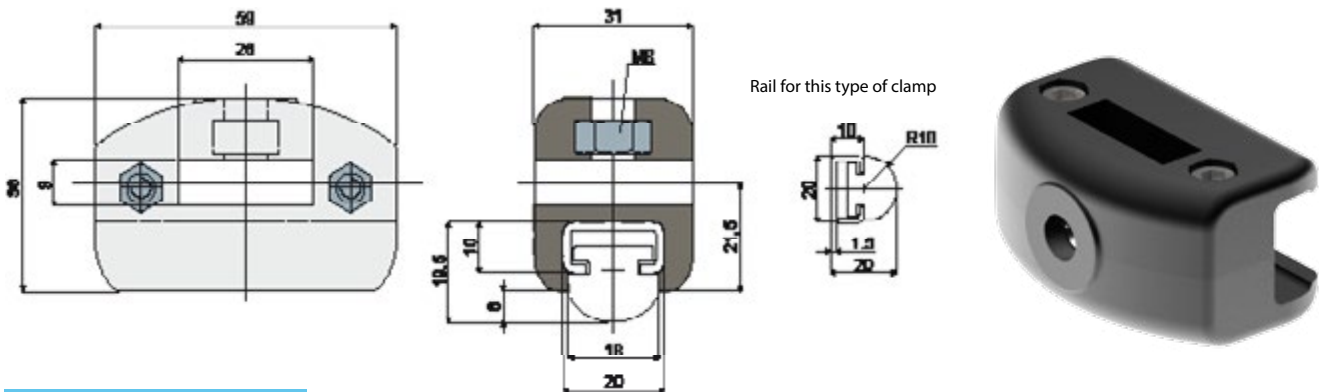

Type	Code
D91	CP000188

MATERIALS: Clamp made of reinforced polyamide black colour; screws and nuts made of stainless steel AISI 304.

FEATURES: Supplied assembled. To be used with flat profile with sizes 25x8 mm.

BOX QUANTITY: 24 pieces.

ON REQUEST:

- Clamps: In reinforced polypropylene, other colours.
- Box Quantity: According to your request.

Guide rail clamp (for trapezoidal rails) Type: T47

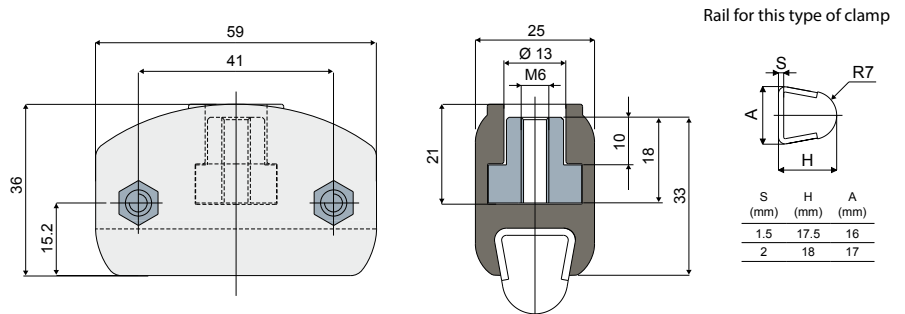

Type	Code
T47	CP000189

MATERIALS: Clamp made of reinforced polyamide black colour; threaded insert in nickel plated brass; bolts and nuts in stainless steel AISI 304.

FEATURES: designed appositely to be assembled directly on the pneumatic cylinder for the rails regulation. Supplied assembled.

BOX QUANTITY: 24 pieces.

ON REQUEST:

- Clamps: In reinforced polypropylene, other colours.
- Box Quantity: According to your request.

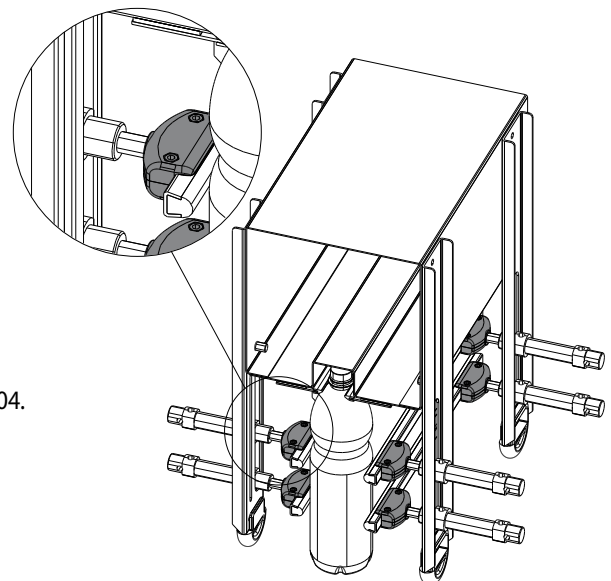

Example of application



Guide rail clamp (for round rails) Type: T48

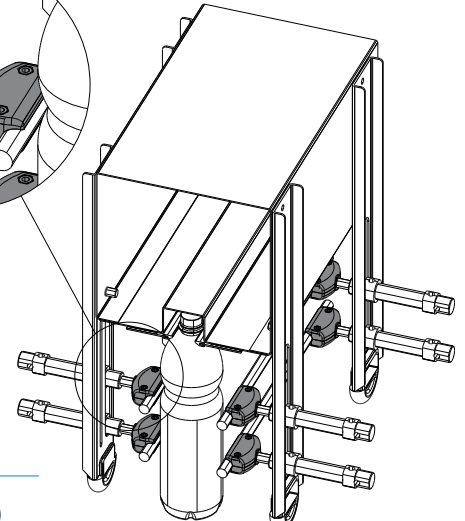
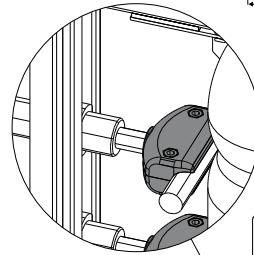
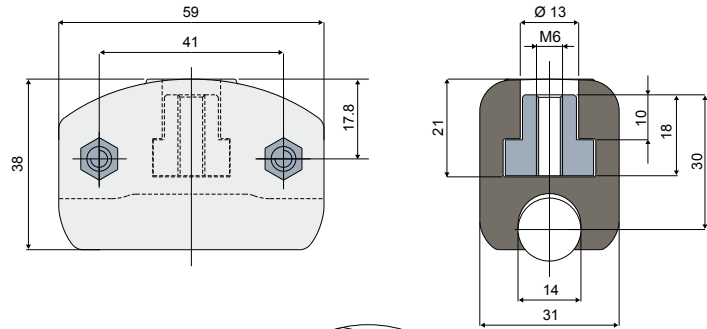

Example of application

Type	Code
T48	CP000190

Guide rail clamp (for rectangular rails) Type: T49

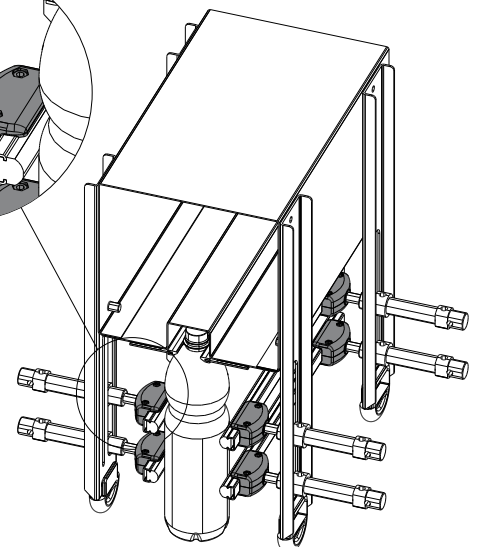
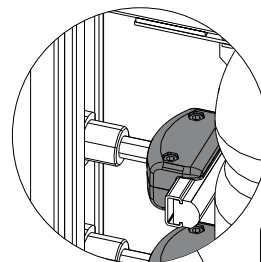
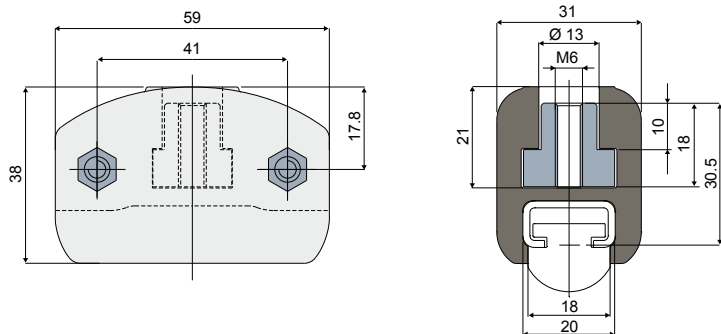

Example of application

Type	Code
T49	CP000191

**MATERIALS:** Clamp made of reinforced polyamide black colour; threaded insert in nickel plated brass; bolts and nuts in stainless steel AISI 304.

**FEATURES:** Designed appositely to be assembled directly on the pneumatic cylinder for the rails regulation. Supplied assembled.

**BOX QUANTITY:** 24 pieces.

**ON REQUEST:**

- Clamps: In reinforced polypropylene, other colours.
- Box Quantity: According to your request.

## Guide rail clamp (for rectangular rail) Type: D90

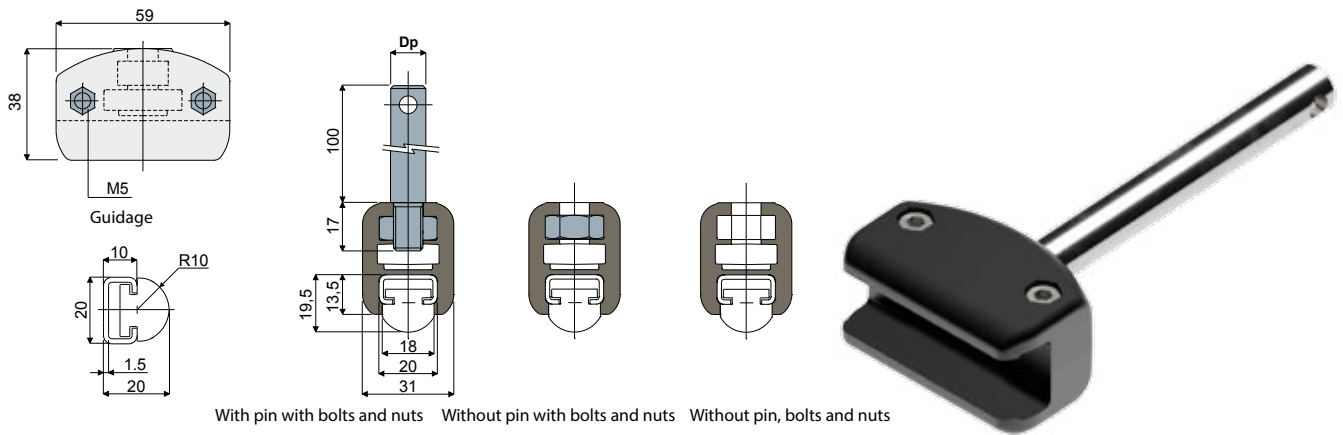

With pin with bolts and nuts    Without pin with bolts and nuts    Without pin, bolts and nuts

Dp Pin diameter (mm)	With pin with bolts and nuts		Without pin with bolts and nuts		Without pin, bolts and nuts	
	Type	Code	Type	Code	Type	Code
12	D90A	CP000192				
14	D90B	CP000193	D90D	CP000195	D90E	CP000196
16	D90C	CP000194				

## Guide rail clamp (for trapezoidal rail) Type: D05

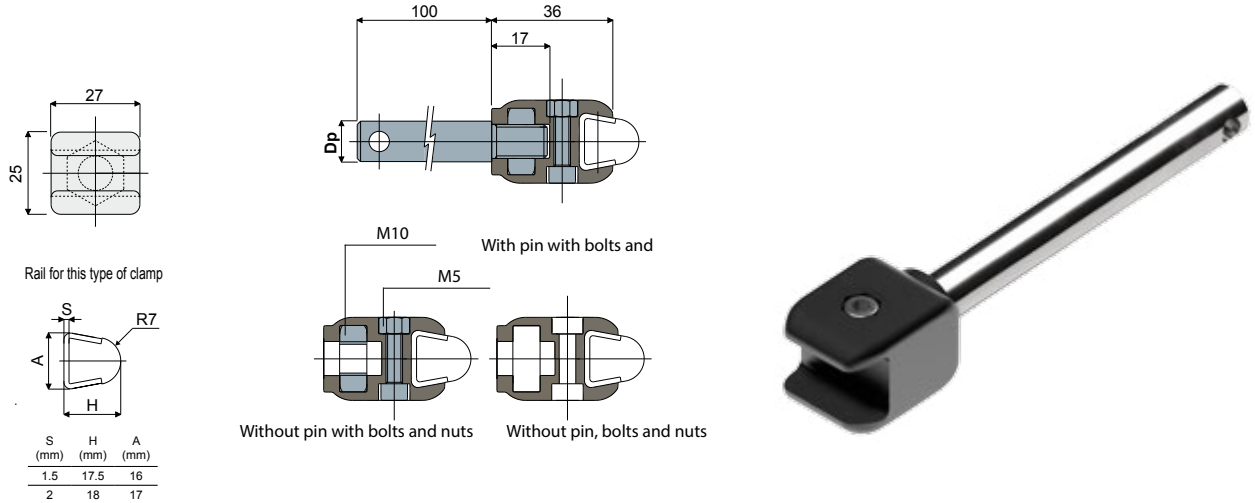

Rail for this type of clamp

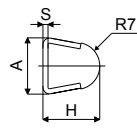

S (mm)	H (mm)	A (mm)
1.5	17.5	16
2	18	17

Without pin with bolts and nuts    Without pin, bolts and nuts

Dp Pin diameter (mm)	With pin with bolts and nuts		Without pin with bolts and nuts		Without pin, bolts and nuts	
	Type	Code	Type	Code	Type	Code
12	D05A	CP000197				
14	D05B	CP000198	D05D	CP000200	D05E	CP000201
16	D05C	CP000199				

**MATERIALS:** Clamp made of reinforced polyamide black colour; pin, bolts and nuts made of stainless steel AISI 304.

**FEATURES:** Supplied with or without support pin and with or without bolts and nuts. D05 can be used with rails with thickness of 1,5 and 2 mm.

**BOX QUANTITY:** 24 pieces.

**ON REQUEST:**

- Clamps: In reinforced polypropylene, other colours.
- Box Quantity: According to your request. Conditionnement: Hors standard.

Guide rail clamp (for round rail) Type: D04

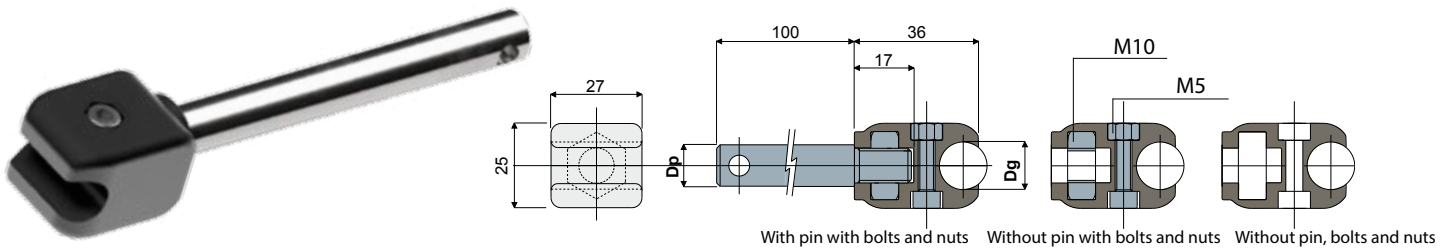

Dp Pin diameter (mm)	Dg Rail diameter (mm)	With pin with bolts and nuts	
		Type	Code
12	8	D04A	CP000202
	10	D04B	CP000203
	12	D04C	CP000204
	14	D04D	CP000205
14	8	D04E	CP000206
	10	D04F	CP000207
	12	D04G	CP000208
	14	D04H	CP000209
16	8	D04I	CP000210
	10	D04L	CP000211
	12	D04M	CP000212
	14	D04N	CP000213

Dg Rail diameter (mm)	Without pin with bolts and nuts	
	Type	Code
8	D04O	CP000214
10	D04P	CP000215
12	D04Q	CP000216
14	D04R	CP000217

Dg Rail diameter (mm)	Without pin	
	Type	Code
8	D04S	CP000218
10	D04T	CP000219
12	D04U	CP000220
14	D04V	CP000221

**MATERIALS:** Clamp made of reinforced polyamide black colour; pin, bolts and nuts made of stainless steel AISI 304.

**FEATURES:** Supplied with or without support pin and with or without bolts and nuts.

**BOX QUANTITY:** 24 pieces.

**ON REQUEST:**

- Clamps: In reinforced polypropylene, other colours.
- Box Quantity: According to your request.

Threaded pin Type: T01

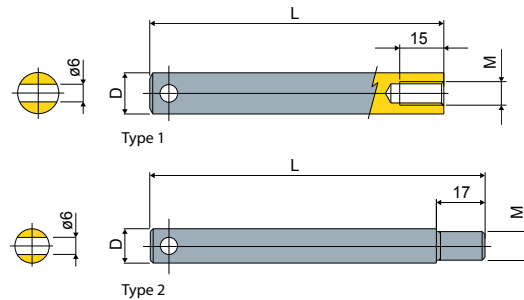

D (mm)	L (mm)	M (mm)	Type 1	
			Type	Code
14	100	M8	T01A	CP000222

D (mm)	L (mm)	M (mm)	Type 2	
			Type	Code
12	117	M10	T01B	CP000223
14	117	M10	T01C	CP000224
16	117	M10	T01D	CP000225

Example of application

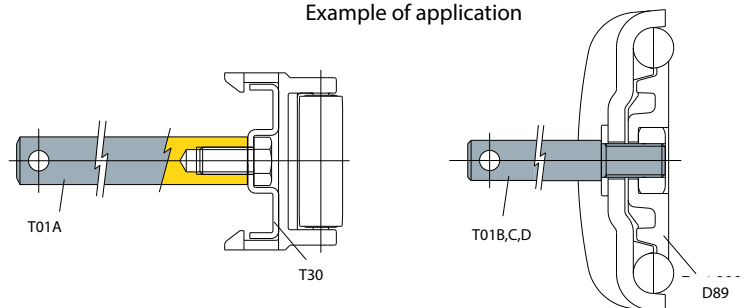

**MATERIALS:** Pin made of stainless steel AISI 304.

**FEATURES:** Type 1: can be mounted both on guide rail clamps or on side guides;

Type 2: used for the mounting of Part. 289, 229, 230, 290, 204, 205.

**BOX QUANTITY:** 24 pieces.

**ON REQUEST:**

- Pins: In various lengths.
- Box Quantity: According to your request.

Spacer for chain profile Type: T02

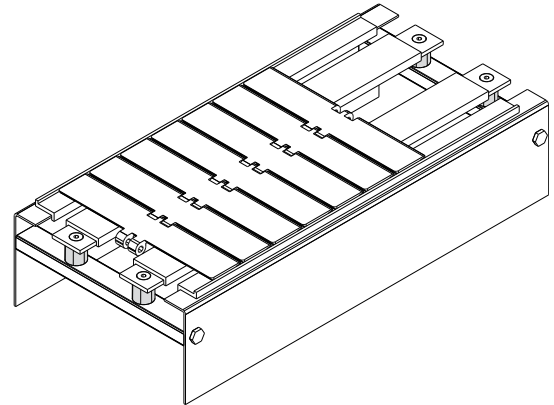
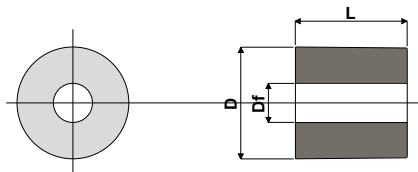

Df Bore diameter (mm)	D (mm)	L (mm)	Type	Code
7	20	20	T02A	CP000226
7	20	27,5	T02B	CP000227

MATERIALS: Spacer made of reinforced polyamide black colour.

FEATURES: To be used as fixing spacer for chain profiles.

BOX QUANTITY: 96 pieces.

ON REQUEST:

- Spacers: With special bores and sizes.
- Box Quantity: According to your request.

Spacer for rail-holder cylinder Type: T16

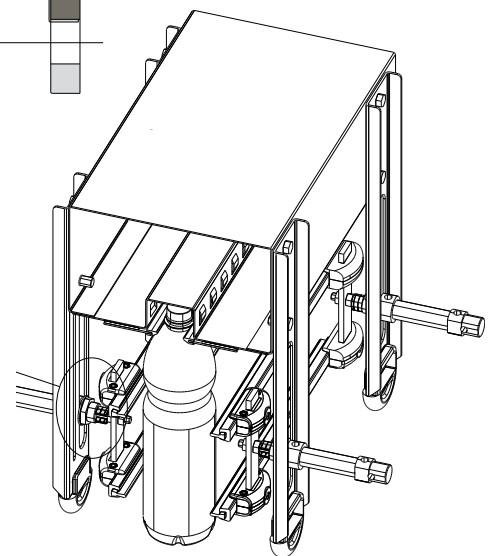
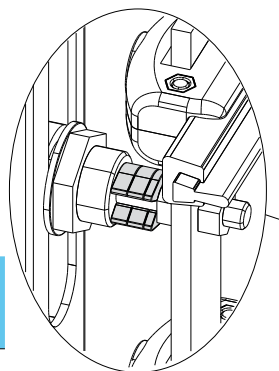
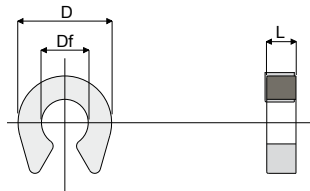

Example of application

Df Bore diameter (mm)	D (mm)	L (mm)	Type	Code
8	16	2,5	T16A	CP000228
8	16	5	T16B	CP000229

MATERIALS: Spacer made of polyamide black colour.

FEATURES: To be used as spacer for the stroke regulation of rail-holder pneumatic cylinder.

BOX QUANTITY: 96 pieces.

ON REQUEST:

- Spacers: With special bores and sizes.
- Box Quantity: According to your request.