

Quality Chains

***Rexnord Expertise
Creating the
highest performance***

***Roller chains
Leaf chains
Rotary chains***

Rexnord Quality Chains - worldwide

Rexnord has been manufacturing chains in many different designs since 1892. The experience gained in many decades as well as consistent research ensures products of an advanced design and a high degree of dependability. Rexnord manufactures at 3 locations on 3 continents. A large number of patents confirm the extraordinary innovative spirit which bears witness to this company. Wherever applications of extreme quality are required, Rexnord products are there, meeting the highest of demands.

Advantages of Rexnord Chains

Roller chains belong to products complying with the DIN Standard, but contrary to widespread opinion, the quality of a chain is not governed by breaking load, but by the ability to survive repeated operating loads and wear life.

True quality is measured in terms of fatigue strength and resistance to wear. This means that in reality, roller chains from different manufacturers with the same tensile strength are not always the same in their quality, despite standardization.

The production methods developed and practiced by Rexnord enable an optimum combination of quality-determining factors such as fatigue strength and resistance to wear.



Rexnord Kette GmbH maintain a quality management system which is reflected in the special commitments to their customers.

The quality management handbook describes the quality management system of Rexnord Kette GmbH.

Thereby all Rexnord customers have access to the information how Rexnord realizes and guarantees their products.

Similarly, all Rexnord employees are provided with guidelines, which help to support and motivate them in their endeavours to work with quality-consciousness.

This handbook contains an all-round binding description, which is according to the internationally-known DIN EN ISO 9001 and DIN EN ISO 14001. Furthermore, process details, working details and testing methods as well as all-round processing practices are available to the employees.

The products from Rexnord and its organisation undergo systematic optimization processes. Consequently, external and internal feedback is followed with eager interest and market-orientated demands observed with a watchful eye, both contributing and correctively improving production processes.

Table of Contents

| | | |
|--|--|---------|
| | Introduction | 4 – 5 |
| | RexPro - the Standard | 6 – 7 |
| | Operational safety and quality criteria | 8 – 9 |
| | Roller chains, European standard, ISO 606 / DIN 8187 | 10 – 11 |
| | Roller chains, American standard, ISO 606 / DIN 8188 / ANSI | 12 – 15 |
| | Roller chains, American standard, ISO 606 / ANSI, H-series | 16 – 17 |
| | Roller chains, American standard, ISO 606 / ANSI, HE-series | 18 – 19 |
| | Roller chains, Industry standard | 20 |
| | Roller chains for heavy drives and lifting applications | 21 |
| | Hoisting chains for straddle carriers | 21 |
| | Roller chains with straight link plates | 21 |
| | RexCarbon - the maintenance-free roller chain | 22 |
| | Hollow pin chains | 23 |
| | RexPlus - roller chains in non-rusting steel | 24 |
| | Side bow roller chains | 25 |
| | Double-pitch roller chains, ISO 1275 / DIN 8181 | 26 |
| | Double-pitch roller chains with straight link plates and carrier rollers, American standard, ISO 1275 | 27 |
| | Agricultural roller chains, ISO 487 / DIN 8189 | 28 |
| | Agricultural roller chains, Industry standard | 29 |
| | Agricultural roller chains with thermoplastic bearings | 29 |
| | Leaf chains acc. to ISO 4347 / DIN 8152, American standard, Heavy series | 30 – 31 |
| | Leaf chains, Industry standard | 32 |
| | Leaf chains, ISO 4347 / DIN 8152, European standard, Light series | 33 |
| | Leaf chains, American standard, Light series | 33 |
| | Fastening of leaf chains | 34 – 36 |
| | Rotary chains | 37 |
| | Laschenkette | 38 – 39 |
| | Marine Diesel Roller chains, ISO 606 / DIN 8187 | 40 – 41 |
| | Fastening dimensions for roller chains, European standard, ISO 606 / DIN 8187 | 42 |
| | Fastening dimensions for roller chains, American standard, ISO 606 / DIN 8188 | 42 |
| | Lubrication and maintenance of Rexnord chains | 43 – 49 |
| | Recommendations for use | 50 |

Thinking and acting like partners



The speed with which our world is changing is breathtaking.

Rexnord will meet these challenges.

Through the use of their products, Rexnord will together with their customers, take up a technical leading position and together with them achieve an increase in quality and turnover.

As manufacturer of one of the most extensive ranges of chains for the field of "drives and conveying", Rexnord is an established partner of leading companies. Over 8.000 variations of chain bear witness to an impressively large number of solutions and a high degree of flexibility.

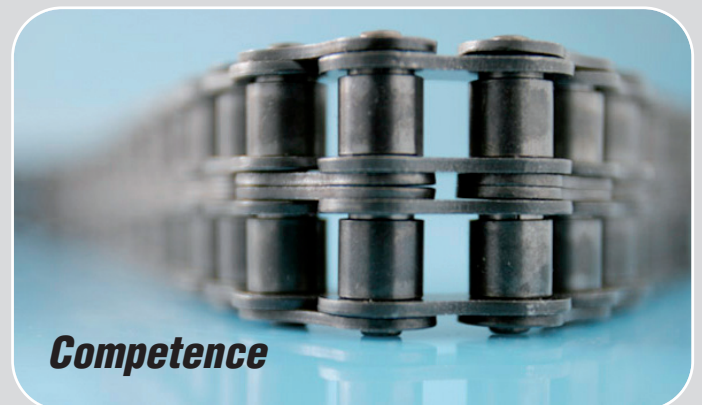

Rexnord knows what the customer requires in his market for his product in the future. Rexnord listens to him and observes the field of "Drives and Conveying" worldwide. Analyses are carried out on-site at the customer and practicable solutions are worked out.

This is done to safeguard the competitiveness of the customer.

Innovation

The secret lies in the production methods and in the materials. Several thousand tools developed by ourselves in accordance with customer wishes, are brought into use in the production processes. 650 special tools have been constructed for producing special chains. 30 special steels, alloyed, rust-resistant or patented are processed. Moreover, Rexnord offers a wide variety of lubricants. Demands made by customers have made Rexnord into a specialist for surface refinement and for heat treatment of steels.

Rexnord application engineers concentrate on the customer's interests. Rexnord concentrates on the individual wishes and requirements of the customer when calculating and identifying the correct chain drives. Rexnord works together with the customer to find solutions which optimize the factors of safety, working life and price.

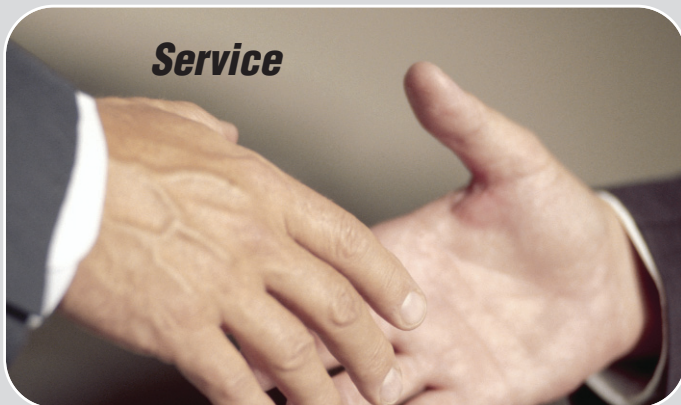

If the customer is satisfied, then Rexnord is satisfied.

High consultative intensity, working together in partnership and the experience of their own sales force constitute the best prerequisites. This is how Rexnord has acquired far-reaching knowledge of the market, technical competence and a high degree of customer satisfaction.



For Rexnord, quality means:
The customer comes back and not the chain.

Superior product quality from Rexnord

Rexnord Kette continues to convince through outstanding product innovations. The primary target is to further improve the performance and use of high performance quality chains. Convince yourself through one of our trained dealers and sales people because Rexnord chains are optimized in performance, not simply in appearance.

RexPro: The performance standard for high performance chains

RexPro covers almost the complete family of standard high performance chains acc. to BS and ANSI, from the sizes 04 B-1 to 72 B-3 and leaf chains from the sizes AL 422 to F 76-88.

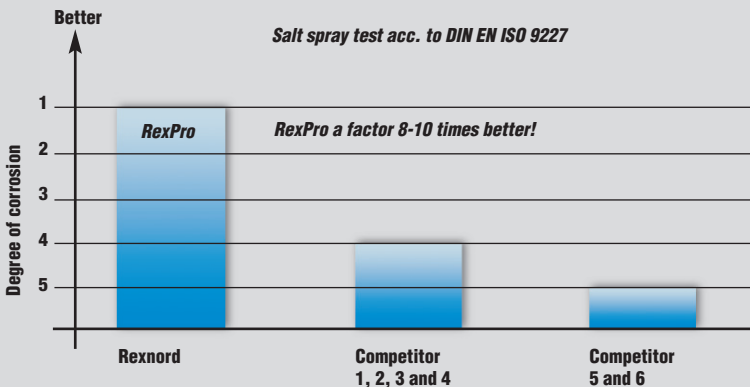

Outstanding corrosion protection!

- protection against stiff chain links

Improved wear protection!

- longer working life

No heavy metals!

- H2 Approval
- conforms to RoHS

RexCarbon: The maintenance-free chain

RexCarbon chains in the sizes 08B-1 to 16 B-1, equipped with bushes made from a high-tech thermoplastic composite material, enable maintenance-free application in especially delicate environments.

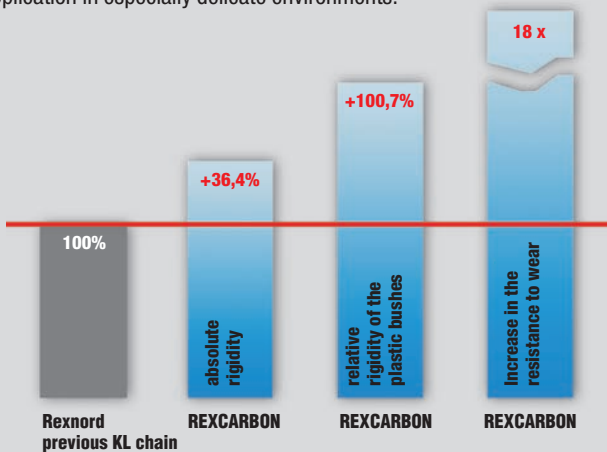

Really maintenance-free!

- no downtime

Absolutely no need for lubricants!

- no contamination of transported goods or surroundings

Use of optimized materials!

- enormously long working life

More robust thanks to carbon fibre!

- improved resistance to wear
- wide-range of applications
- a clean solution for many applications

RexPlus: The high performance rust-free and acid-resistant chain

RexPlus chains display an especially high strength and an optimized wear characteristic through the use of patented special steel and through the use of ferritic-martensitic material for the chain links.

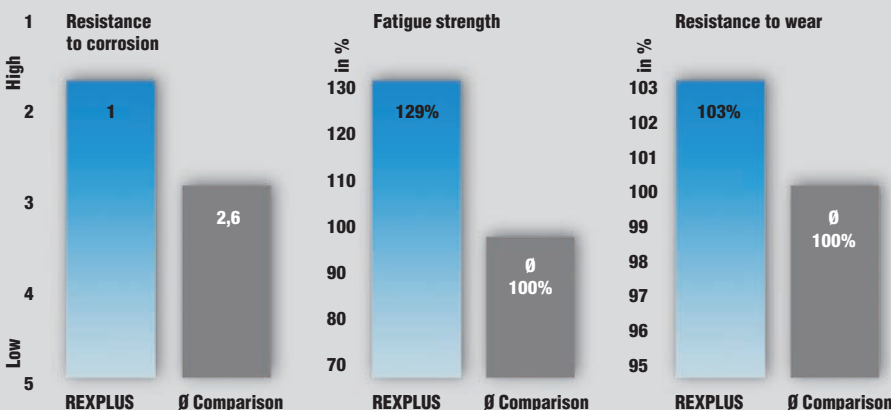

Extremely rust and acid-resistant!

- highest standard for roller chains

New selection of materials for link components!

- improved resistance to wear

Improved production processes!

- optimized fatigue strength

Patented material!

- higher fatigue strength compared to commercially available "rust-free chains"

Special surface treatment!

- outstanding resistance to corrosion

RexPro - The standard for quality chains:

The new RexPro chain is the result of further-developing the Rexnord high performance chain. Over a timespan of more than 4 years the combination of selected steels, optimized manufacturing and the new RexPro lubrication have all achieved these outstanding product characteristics:

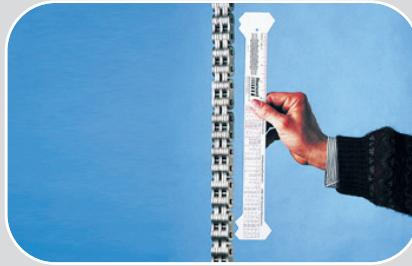

Superior Corrosion protection

RexPro-Roller chains are a factor of 8 -10 times better than the best competitor for European and Asian quality roller chains, tested according to the Salt-Spray Test DIN EN ISO 9227

RexPro chains are more than 100% better than the competitors in the Stiffness Test in aggressive surroundings.

Results in:

- ▶ optically-appealing chains, also in mounted condition, even after long storage or after sea transport
- ▶ no re-working required on delivery
- ▶ improved protection against stiffened chain links
- ▶ longer working life

Improved wear resistance

The new RexPro high performance chain possesses an 8 -12% improved protection against wear in comparison to its previous version.

In contrast to existing standard lubrication, the RexPro lubricant offers a more than 150% better protection against cold welding (DIN 51834).

Results in:

- ▶ longer working life
- ▶ improved economy

Excellent environmental characteristics

The new lubrication for RexPro contains no heavy metals, no Teflon and no Silicon and thereby offers a wide spectrum of applications.

Rexnord possesses an environment management system according to ISO 14001:2005

Results in:

- ▶ NSF-H2 approval for food industry
- ▶ RoHS conformaty for electric-/electronics branch
- ▶ RexPro fulfils the environmental criteria of market-leading manufacturers

Stiffness Test



| Industries: | Corrosion protection | Wear protection | Environmental compatibility | Suitability for foodstuffs | Cleanliness | Droplet spin-off | Anti-drip security | Lack of lubrication | Paint compatibility |
|------------------------------------|----------------------|-----------------|-----------------------------|----------------------------|-------------|------------------|--------------------|---------------------|---------------------|
| Automobile industry | | | | | | | | | |
| Drinks/beverages and filling plant | | | | | | | | | |
| Textile industry | | | | | | | | | |
| Food and confectionary industry | | | | | | | | | |
| Packaging industry | | | | | | | | | |
| Conveying technology | | | | | | | | | |
| Pharmaceuticals industry | | | | | | | | | |
| Paper and wood processing | | | | | | | | | |
| Machine and plant construction | | | | | | | | | |
| Agricultural technology | | | | | | | | | |

✔

Optimum Performance



High case hardness

The pins and bushes that make up the chain-bearing area are furnished with an optimally deep hardness layer. This layer is mainly responsible for increasing, i.e. lengthening the working life. Specially selected high performance steels enable absolute and uniform, 1st class product characteristics.

The RexPro lubrication is compatible with commercially available mineral and synthetic oils.

An additional advantage is offered by the anti-drip consistency of the new lubricant, even at high temperatures.

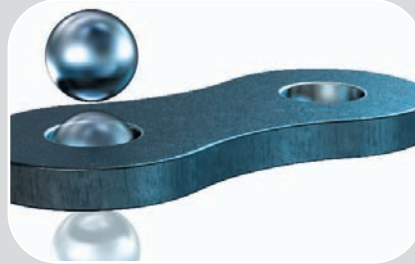

Improved pressfit

Ball-drifting of the plate bores serves to achieve strain-hardening of the material. All punching flutes and sharp edges are simultaneously removed. The resulting effect is a significant improvement in the press fits and the fatigue strength.



Intensive shot peening

All pins, plates, bushes and rollers are shot-peened to further improve the fatigue strength. This effective cold-working additionally consolidates the surface and increases the load-bearing characteristics.

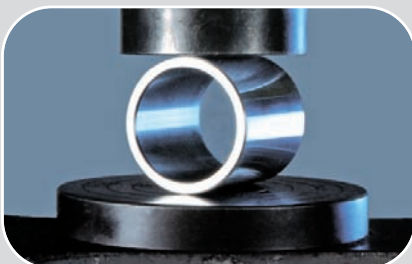

Seam-free rollers

Rexnord rollers are characterised by their high fatigue strength against running-in impacts. This has been reached through special heat treatment and intensive shot-peening. The seam-free surface guarantees an outstanding load-bearing area and smooth, quiet running.

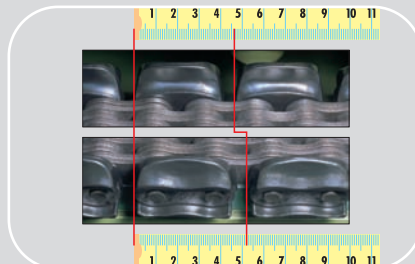

High pre-loading

After assembly, the chain is subject to a high tensile load which minimises the initial stretch that all chains experience during the first hours of use.



Uniform quality

The uniform quality of Rexnord chains is not merely ensured by initial and final inspections, but also by in-process routine testing of the individual components.

Rexnord quality features

Fatigue strength

The fatigue strength is defined as the value of the repeated operational and pulsating loads, imposed by the sprocket polygon effect or changing loads that the chain can withstand without suffering failure from metal fatigue.

To achieve high fatigue strength, and not counting on production engineering and materialistic influences - the determination of tensile strength plays a not unimportant role. When the breaking force is too high, this can be seen as a disadvantage because it is related to a reduction in the toughness and fatigue strength values.

If the tensile strength of a chain is increased above a certain value then the decisive value for the fatigue strength is reduced considerably.

Ultimate strength

The stated value given for ultimate tensile strength is of little significance, because just before reaching the breaking point - above the yield point - it will take up a permanent deformation, rendering the chain unusable. The tensile strength defines only the limit at which the chain breaks. The chain loses its functionality however long before this- as soon as it has passed the limit of elasticity.

Limit of elasticity

The limit of elasticity sets the upper limit under which there is no permanent plastic deformation which would render the chain unusable. Below this limit loads and operational shocks cause elastic elongation which lasts only as long as the loading effect.

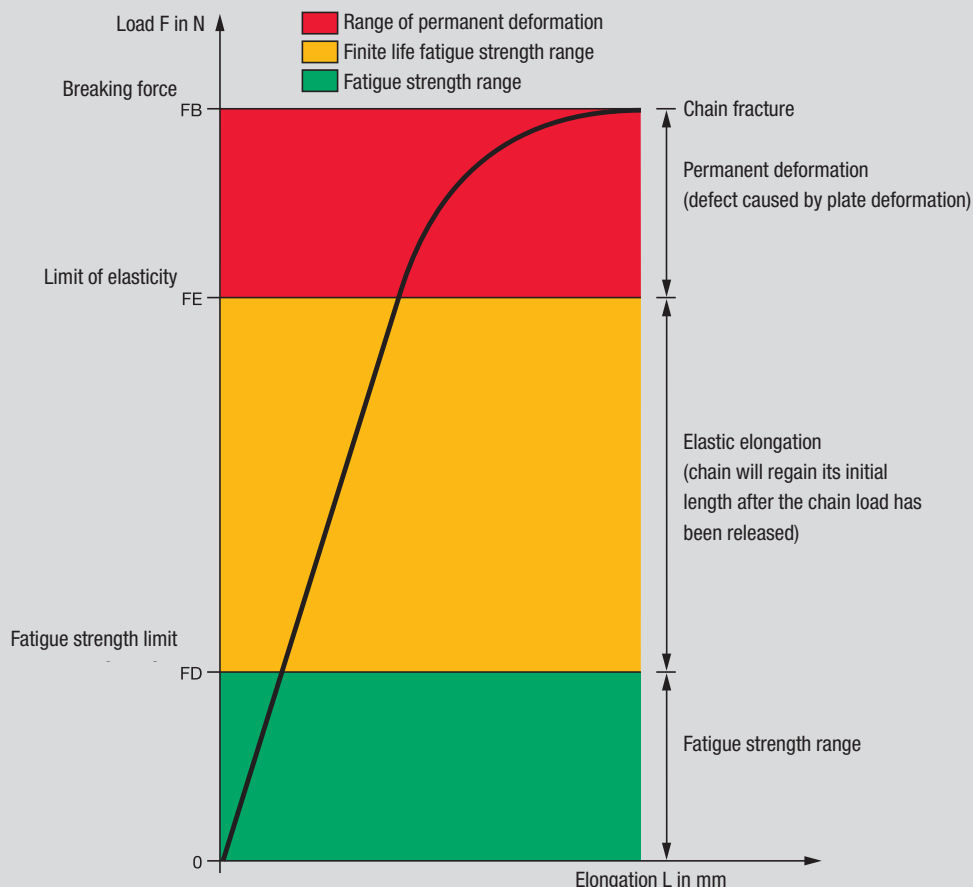

Are you aware that:

For design specifications it is the values for elasticity and fatigue strength that are of importance. If required, please contact Rexnord for these values. All tensile strength values for roller, leaf and rotary chains are the minimum values as laid down in the DIN specification; these in fact play only a minor role in the functionality of the chains. Be aware that average values are unreliable as the basis for design or decision unless qualified by the tolerance band that can be expected. The German Standards Committee - DIN - demands all tensile strength values as a minimum value, and this is always fulfilled by Rexnord products.

Roller chains, European standard



High performance roller chains.

The links A and B are available for all chains.

- with straight link plates on page 21.
- higher inner plate "g" = higher fatigue strength.

Roller chains, single strand ISO 606 / DIN 8187

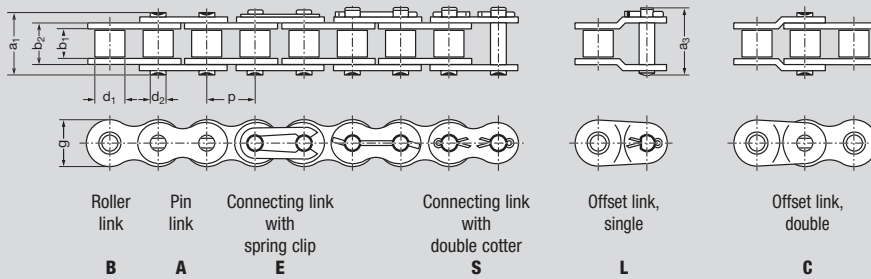

| ISO-Nr. | Pitch p | | Roller width b ₁ min. mm | Roller Ø d ₁ max. mm | Pin Ø d ₂ max. mm | Inner width b ₂ max. mm | Link plate height g mm | Transverse e mm | Pin length a ₁ max. mm | Overall width a ₃ max. mm | Bearing area A cm ² | Min. ultimate strength required*) acc. to DIN/ISO F _B N | Weight ≈ q kg/m | Loose parts | | | |
|------------|---------|--------|--|------------------------------------|---------------------------------|---------------------------------------|---------------------------|--------------------|--------------------------------------|---|-----------------------------------|--|--------------------|-------------|---|---|---|
| | inch | mm | | | | | | | | | | | | S | C | E | L |
| 04 | | 6.0 | 2.80 | 4.00 | 1.85 | 4.1 | 5.0 | – | 7.4 | 10.3 | 0.08 | 3 000 | 0.12 | x | x | | |
| 05 B – 1 | | 8.0 | 3.00 | 5.00 | 2.31 | 4.77 | 7.1 | – | 8.6 | 11.7 | 0.11 | 5 000 | 0.18 | x | x | | |
| ■ 06 B – 1 | 0.375 | 9.525 | 5.72 | 6.35 | 3.28 | 8.53 | 8.2 | – | 13.5 | 16.8 | 0.28 | 9 000 | 0.41 | x | x | | |
| 083 | 0.50 | 12.7 | 4.88 | 7.75 | 4.09 | 7.9 | 10.3 | – | 12.9 | 14.4 | 0.32 | 12 000 | 0.42 | x | x | x | |
| 084 | 0.50 | 12.7 | 4.88 | 7.75 | 4.09 | 8.8 | 11.1 | – | 14.8 | 16.3 | 0.326 | 16 000 | 0.6 | x | x | x | |
| ■ 08 B – 1 | 0.50 | 12.7 | 7.75 | 8.51 | 4.45 | 11.3 | 11.6 | – | 17.0 | 20.9 | 0.50 | 18 000 | 0.7 | x | x | x | |
| ■ 10 B – 1 | 0.625 | 15.875 | 9.65 | 10.16 | 5.08 | 13.28 | 14.6 | – | 19.6 | 23.7 | 0.67 | 22 400 | 0.9 | x | x | x | |
| ■ 12 B – 1 | 0.75 | 19.05 | 11.68 | 12.07 | 5.72 | 15.62 | 15.9 | – | 22.7 | 27.3 | 0.89 | 29 000 | 1.15 | x | x | x | |
| ■ 16 B – 1 | 1.00 | 25.4 | 17.02 | 15.88 | 8.28 | 25.4 | 20.5 | – | 36.1 | 42.4 | 2.10 | 60 000 | 2.6 | x | x | x | x |
| ■ 20 B – 1 | 1.25 | 31.75 | 19.56 | 19.05 | 10.19 | 29.0 | 25.7 | – | 40.4 | 47.6 | 2.96 | 95 000 | 3.7 | x | | | x |
| ■ 24 B – 1 | 1.50 | 38.1 | 25.40 | 25.40 | 14.63 | 37.9 | 33.0 | – | 53.8 | 60.6 | 5.54 | 160 000 | 6.9 | x | | | x |
| ■ 28 B – 1 | 1.75 | 44.45 | 30.99 | 27.94 | 15.90 | 46.5 | 37.0 | – | 63.3 | 72.8 | 7.39 | 200 000 | 8.6 | x | | | x |
| ■ 32 B – 1 | 2.00 | 50.8 | 30.99 | 29.21 | 17.81 | 45.5 | 41.2 | – | 65.1 | 73.6 | 8.10 | 250 000 | 9.5 | x | | | x |
| ■ 40 B – 1 | 2.50 | 63.5 | 38.10 | 39.37 | 22.89 | 55.7 | 51.5 | – | 78.9 | 91.3 | 12.75 | 355 000 | 15.1 | x | | | x |
| ■ 48 B – 1 | 3.00 | 76.2 | 45.72 | 48.26 | 29.24 | 70.5 | 63.5 | – | 98.5 | 124.0 | 20.61 | 560 000 | 24.5 | x | | | x |
| ■ 56 B – 1 | 3.50 | 88.9 | 53.34 | 53.98 | 34.32 | 81.3 | 77.0 | – | 114.7 | 140.0 | 27.90 | 850 000 | 36.5 | x | | | |
| ○ 64 B – 1 | 4.00 | 101.6 | 60.96 | 63.50 | 39.40 | 92.0 | 93.3 | – | 130.0 | 143.0 | 36.25 | 1 120 000 | 50.0 | x | | | |
| ○ 72 B – 1 | 4.50 | 114.3 | 68.58 | 72.39 | 44.50 | 103.8 | 105.3 | – | 147.0 | 161.0 | 46.19 | 1 400 000 | 65.0 | x | | | |

*) Details about the effective higher Rexnord ultimate strengths and fatigue strength values are available upon request.

Roller chains, double-strand ISO 606 / DIN 8187

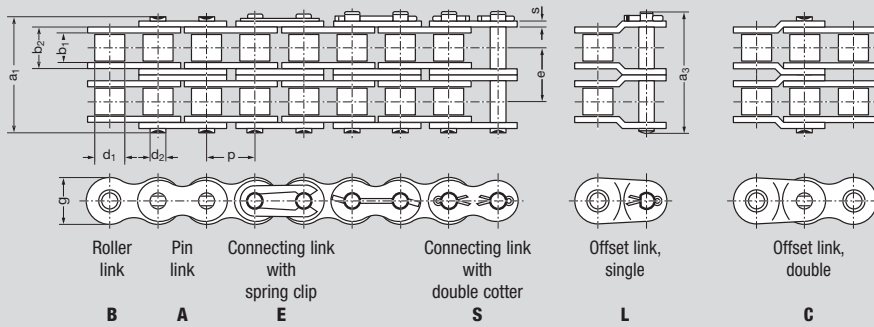

| ISO-Nr. | Pitch p | | Roller width b ₁ min. mm | Roller Ø d ₁ max. mm | Pin Ø d ₂ max. mm | Inner width b ₂ max. mm | Link plate height g mm | Transverse e mm | Pin length a ₁ max. mm | Overall width a ₃ max. mm | Bearing area A cm ² | Min. ultimate strength required*) acc. to DIN/ISO F _B N | Weight ≈ q kg/m | Loose parts | | | |
|------------|------------|--------|--|------------------------------------|---------------------------------|---------------------------------------|---------------------------|--------------------|--------------------------------------|---|-----------------------------------|--|--------------------|-------------|---|---|---|
| | inch | mm | | | | | | | | | | | | S | C | E | L |
| | ■ 06 B - 2 | 0.375 | 9.525 | 5.72 | 6.35 | 3.28 | 8.53 | 8.2 | 10.24 | 23.8 | 27.1 | 0.56 | 16 900 | 0.78 | | x | x |
| ■ 08 B - 2 | 0.50 | 12.7 | 7.75 | 8.51 | 4.45 | 11.3 | 11.6 | 13.92 | 31.0 | 33.0 | 1.01 | 32 000 | 1.4 | | x | x | x |
| ■ 10 B - 2 | 0.625 | 15.875 | 9.65 | 10.16 | 5.08 | 13.28 | 14.6 | 16.59 | 36.2 | 38.6 | 1.34 | 44 500 | 1.8 | | x | x | x |
| ■ 12 B - 2 | 0.75 | 19.05 | 11.68 | 12.07 | 5.72 | 15.62 | 15.9 | 19.46 | 42.2 | 44.4 | 1.79 | 57 800 | 2.3 | | x | x | x |
| ■ 16 B - 2 | 1.00 | 25.4 | 17.02 | 15.88 | 8.28 | 25.4 | 20.5 | 31.88 | 68.0 | 74.0 | 4.21 | 106 000 | 5.3 | x | x | x | x |
| ■ 20 B - 2 | 1.25 | 31.75 | 19.56 | 19.05 | 10.19 | 29.0 | 25.7 | 36.45 | 76.9 | 83.6 | 5.91 | 170 000 | 7.25 | x | | | x |
| ■ 24 B - 2 | 1.50 | 38.1 | 25.40 | 25.40 | 14.63 | 37.9 | 33.0 | 48.36 | 102.2 | 112.7 | 11.09 | 280 000 | 13.75 | x | | | x |
| ■ 28 B - 2 | 1.75 | 44.45 | 30.99 | 27.94 | 15.90 | 46.5 | 37.0 | 59.56 | 122.8 | 132.7 | 14.79 | 360 000 | 17.3 | x | | | x |
| ■ 32 B - 2 | 2.00 | 50.8 | 30.99 | 29.21 | 17.81 | 45.5 | 41.2 | 58.55 | 123.6 | 132.4 | 16.21 | 450 000 | 18.8 | x | | | x |
| ■ 40 B - 2 | 2.50 | 63.5 | 38.10 | 39.37 | 22.89 | 55.7 | 51.5 | 72.29 | 151.2 | 163.8 | 25.50 | 630 000 | 29.9 | x | | | x |
| ■ 48 B - 2 | 3.00 | 76.2 | 45.72 | 48.26 | 29.24 | 70.5 | 63.5 | 91.21 | 189.7 | 215.2 | 41.23 | 1 000 000 | 48.6 | x | | | x |
| ■ 56 B - 2 | 3.50 | 88.9 | 53.34 | 53.98 | 34.32 | 81.3 | 77.0 | 106.60 | 221.3 | 246.5 | 55.80 | 1 600 000 | 72.5 | x | | | |
| ○ 64 B - 2 | 4.00 | 101.6 | 60.96 | 63.50 | 39.40 | 92.0 | 93.3 | 119.89 | 250.0 | 263.0 | 72.50 | 2 000 000 | 98.0 | x | | | |
| ○ 72 B - 2 | 4.50 | 114.3 | 68.58 | 72.39 | 44.50 | 103.8 | 105.3 | 136.27 | 283.0 | 297.0 | 92.40 | 2 500 000 | 128.0 | x | | | |

Roller chains, triple-strand ISO 606 / DIN 8187

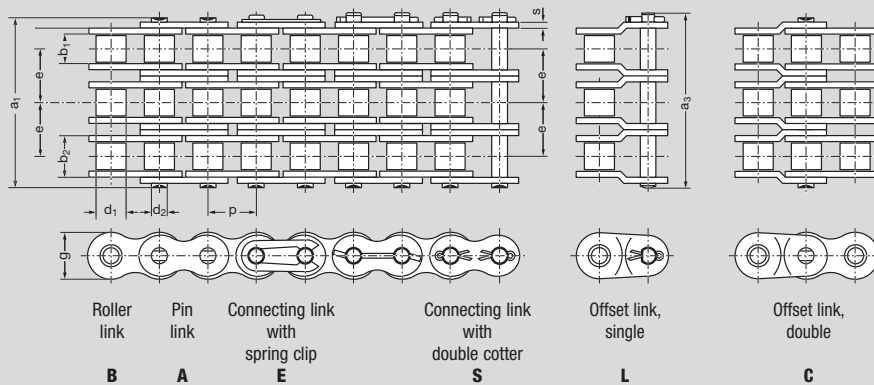

| ISO-Nr. | Pitch p | | Roller width b ₁ min. mm | Roller Ø d ₁ max. mm | Pin Ø d ₂ max. mm | Inner width b ₂ max. mm | Link plate height g mm | Transverse e mm | Pin length a ₁ max. mm | Overall width a ₃ max. mm | Bearing area A cm ² | Min. ultimate strength required*) acc. to DIN/ISO F _B N | Weight ≈ q kg/m | Loose parts | | | |
|------------|------------|--------|--|------------------------------------|---------------------------------|---------------------------------------|---------------------------|--------------------|--------------------------------------|---|-----------------------------------|--|--------------------|-------------|---|---|---|
| | inch | mm | | | | | | | | | | | | S | C | E | L |
| | ■ 06 B - 3 | 0.375 | 9.525 | 5.72 | 6.35 | 3.28 | 8.53 | 8.2 | 10.24 | 34.0 | 37.3 | 0.84 | 24 900 | 1.18 | | x | x |
| ■ 08 B - 3 | 0.50 | 12.7 | 7.75 | 8.51 | 4.45 | 11.3 | 11.6 | 13.92 | 44.9 | 47.2 | 1.51 | 47 500 | 2.1 | | x | x | x |
| ■ 10 B - 3 | 0.625 | 15.875 | 9.65 | 10.16 | 5.08 | 13.28 | 14.6 | 16.59 | 52.8 | 55.6 | 2.02 | 66 700 | 2.6 | | x | x | x |
| ■ 12 B - 3 | 0.75 | 19.05 | 11.68 | 12.07 | 5.72 | 15.62 | 15.9 | 19.46 | 61.7 | 65.2 | 2.68 | 86 700 | 3.4 | | x | x | x |
| ■ 16 B - 3 | 1.00 | 25.4 | 17.02 | 15.88 | 8.28 | 25.4 | 20.5 | 31.88 | 99.9 | 107.2 | 6.31 | 160 000 | 7.8 | | x | x | x |
| ■ 20 B - 3 | 1.25 | 31.75 | 19.56 | 19.05 | 10.19 | 29.0 | 25.7 | 36.45 | 113.4 | 121.2 | 8.87 | 250 000 | 10.85 | x | | | x |
| ■ 24 B - 3 | 1.50 | 38.1 | 25.40 | 25.40 | 14.63 | 37.9 | 33.0 | 48.36 | 150.5 | 160.4 | 16.63 | 425 000 | 20.5 | x | | | x |
| ■ 28 B - 3 | 1.75 | 44.45 | 30.99 | 27.94 | 15.90 | 46.5 | 37.0 | 59.56 | 182.3 | 192.2 | 22.18 | 530 000 | 25.75 | x | | | x |
| ■ 32 B - 3 | 2.00 | 50.8 | 30.99 | 29.21 | 17.81 | 45.5 | 41.2 | 58.55 | 182.2 | 191.0 | 24.31 | 670 000 | 27.95 | x | | | x |
| ■ 40 B - 3 | 2.50 | 63.5 | 38.10 | 39.37 | 22.89 | 55.7 | 51.5 | 72.29 | 223.5 | 236.1 | 38.25 | 950 000 | 44.8 | x | | | x |
| ■ 48 B - 3 | 3.00 | 76.2 | 45.72 | 48.26 | 29.24 | 70.5 | 63.5 | 91.21 | 281.0 | 306.5 | 61.84 | 1 500 000 | 72.5 | x | | | x |
| ■ 56 B - 3 | 3.50 | 88.9 | 53.34 | 53.98 | 34.32 | 81.3 | 77.0 | 106.60 | 328.0 | 353.2 | 83.71 | 2 240 000 | 109.0 | x | | | |

64 B - 3 and 72 B - 3 on request.

*) Details about the effective higher Rexnord ultimate strengths and fatigue strength values are available upon request.

Roller chains, American standard



Optimum constructive and technical coordination of individual chain parts.

Note:

For roller chains of the American standard ANSI 140 to ANSI 240 and the Heavy chains 60 H to 200 - see the next pages.

Available upon request: the oilfield roller chains catalogue with 4 to 8-strand ANSI-roller chains. Links A and B are available for all chains.

Please take note of the different connecting link design and versions of cotters for the chains ANSI 140 to ANSI 240 in comparison with the chains on this page.

- bushed chain
- with straight link plates on page 21.
- 1) bushing \varnothing up to ANSI 50- riveted, from ANSI 60 available as riveted or cottered.

Roller chains, single-strand ISO 606 / DIN 8188

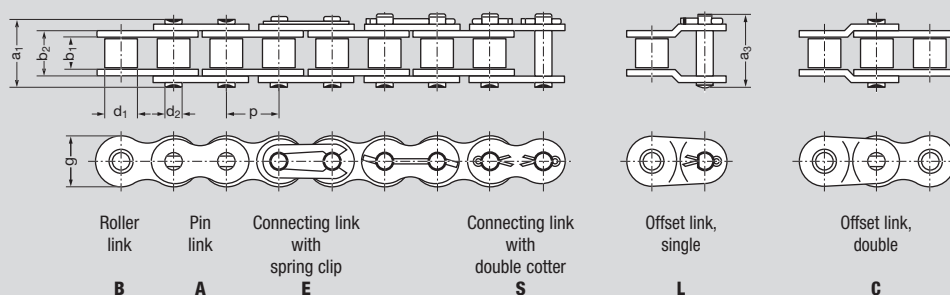

| ANSI-Nr. | Pitch p | | Roller width b ₁ min. mm | Roller \varnothing d ₁ max. mm | Pin \varnothing d ₂ max. mm | Inner width b ₂ max. mm | Link plate height g mm | Transverse e mm | Pin length a ₁ max. mm | Overall width a ₃ max. mm | Bearing area A cm ² | Min. ultimate strength required*) acc. to DIN/ISO F _B N | Weight ≈ q kg/m | Loose parts | | | |
|----------|---------|--------|--|--|---|---------------------------------------|---------------------------|--------------------|--------------------------------------|---|-----------------------------------|--|--------------------|-------------|---|---|---|
| | inch | mm | | | | | | | | | | | | S | C | E | L |
| 40 - 1 | 0.50 | 12.7 | 7.85 | 7.95 | 3.96 | 11.15 | 11.6 | - | 16.3 | 19.1 | 0.44 | 14 100 | 0.62 | | x | x | x |
| 50 - 1 | 0.625 | 15.875 | 9.40 | 10.16 | 5.08 | 13.8 | 14.6 | - | 20.3 | 23.0 | 0.70 | 22 200 | 1.01 | | x | x | x |
| ■ 60 - 1 | 0.75 | 19.05 | 12.57 | 11.91 | 5.94 | 17.7 | 17.7 | - | 25.7 | 28.6 | 1.05 | 31 800 | 1.48 | x | x | x | x |
| ■ 80 - 1 | 1.00 | 25.4 | 15.75 | 15.88 | 7.92 | 22.5 | 23.5 | - | 33.0 | 38.0 | 1.78 | 56 700 | 2.60 | x | x | x | x |
| 100 - 1 | 1.25 | 31.75 | 18.90 | 19.05 | 9.53 | 27.4 | 29.2 | - | 39.4 | 44.9 | 2.61 | 88 500 | 3.76 | x | | | x |
| 120 - 1 | 1.50 | 38.1 | 25.22 | 22.23 | 11.10 | 35.3 | 34.4 | - | 49.8 | 56.1 | 3.92 | 127 000 | 5.50 | x | | | x |

*) Details about the effective higher Rexnord ultimate strengths and fatigue strength values are available upon request.

Roller chains, double-strand ISO 606 / DIN 8188

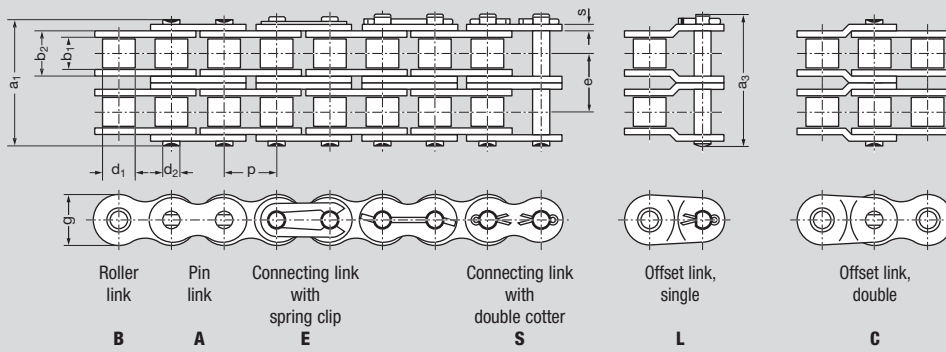

| ANSI-Nr. | Pitch p | | Roller width b ₁ min. mm | Roller Ø d ₁ max. mm | Pin Ø d ₂ max. mm | Inner width b ₂ max. mm | Link plate height g mm | Transverse e mm | Pin length a ₁ max. mm | Overall width a ₃ max. mm | Bearing area A cm ² | Min. ultimate strength required*) acc. to DIN/ISO F _B N | Weight ≈ q kg/m | Loose parts | | | |
|----------|---------|--------|--|------------------------------------|---------------------------------|---------------------------------------|---------------------------|--------------------|--------------------------------------|---|-----------------------------------|--|--------------------|-------------|---|---|---|
| | inch | mm | | | | | | | | | | | | S | C | E | L |
| 40-2 | 0.50 | 12.7 | 7.85 | 7.95 | 3.96 | 11.15 | 11.6 | 14.38 | 30.7 | 33.5 | 0.88 | 28 200 | 1.22 | | | x | x |
| 50-2 | 0.625 | 15.875 | 9.40 | 10.16 | 5.08 | 13.8 | 14.6 | 18.11 | 38.5 | 41.3 | 1.40 | 44 400 | 2.00 | | x | x | x |
| 60-2 | 0.75 | 19.05 | 12.57 | 11.91 | 5.94 | 17.7 | 17.7 | 22.78 | 48.5 | 51.5 | 2.10 | 63 600 | 2.95 | x | | x | x |
| 80-2 | 1.00 | 25.4 | 15.75 | 15.88 | 7.92 | 22.5 | 23.5 | 29.29 | 62.4 | 67.1 | 3.56 | 113 400 | 5.20 | x | | | x |
| 100-2 | 1.25 | 31.75 | 18.90 | 19.05 | 9.53 | 27.4 | 29.2 | 35.76 | 75.3 | 87.8 | 5.22 | 177 000 | 7.60 | x | | | x |
| 120-2 | 1.50 | 38.1 | 25.22 | 22.23 | 11.1 | 35.3 | 34.4 | 45.44 | 95.3 | 101.6 | 7.84 | 254 000 | 10.80 | x | | | x |

Roller chains, triple-strand ISO 606 / DIN 8188

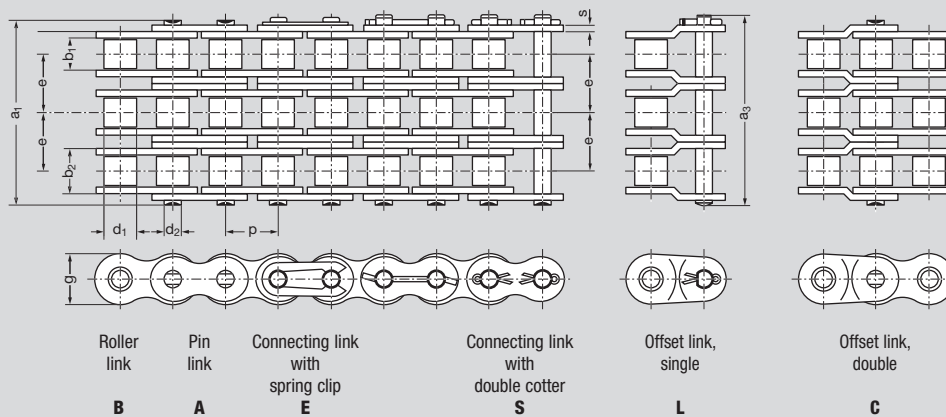

| ANSI-Nr. | Pitch p | | Roller width b ₁ min. mm | Roller Ø d ₁ max. mm | Pin Ø d ₂ max. mm | Inner width b ₂ max. mm | Link plate height g mm | Transverse e mm | Pin length a ₁ max. mm | Overall width a ₃ max. mm | Bearing area A cm ² | Min. ultimate strength required*) acc. to DIN/ISO F _B N | Weight ≈ q kg/m | Loose parts | | | |
|----------|---------|--------|--|------------------------------------|---------------------------------|---------------------------------------|---------------------------|--------------------|--------------------------------------|---|-----------------------------------|--|--------------------|-------------|---|---|---|
| | inch | mm | | | | | | | | | | | | S | C | E | L |
| 40-3 | 0.50 | 12.7 | 7.85 | 7.95 | 3.96 | 11.15 | 11.6 | 14.48 | 45.1 | 48.0 | 1.32 | 42 300 | 1.83 | | | x | x |
| 50-3 | 0.625 | 15.875 | 9.40 | 10.16 | 5.08 | 13.8 | 14.6 | 18.11 | 56.7 | 59.8 | 2.10 | 66 600 | 2.97 | | | x | x |
| 60-3 | 0.75 | 19.05 | 12.57 | 11.91 | 5.94 | 17.7 | 17.7 | 22.78 | 71.4 | 75.6 | 3.15 | 95 400 | 4.35 | x | | x | x |
| 80-3 | 1.00 | 25.4 | 15.75 | 15.88 | 7.92 | 22.5 | 23.5 | 29.29 | 91.7 | 97.7 | 5.35 | 170 100 | 7.90 | x | | | x |
| 100-3 | 1.25 | 31.75 | 18.90 | 19.05 | 9.53 | 27.4 | 29.2 | 35.76 | 111.1 | 117.2 | 7.83 | 265 500 | 11.40 | x | | | x |
| 120-3 | 1.50 | 38.1 | 25.22 | 22.23 | 11.10 | 35.3 | 34.4 | 45.44 | 140.7 | 148.3 | 11.76 | 381 000 | 15.80 | x | | | x |

*) Details about the effective higher Rexnord ultimate strengths and fatigue strength values are available upon request.

Roller chains, American standard



Large pitch roller chains for the highest of demands.

Links A and B are available for all chains.

Roller chains, single-strand ISO 606 / DIN 8188

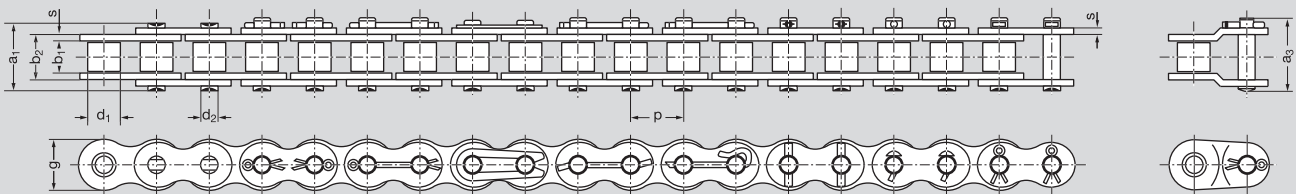

| | | | | | | | |
|-------------|----------|-----------|-----------|------------------------------------|-----------|------------------------------------|---------------------|
| Roller link | Pin link | Pin link | Pin link | Connecting link with T-head cotter | Pin link | Connecting link with double cotter | Offset link, single |
| B | A | AS | AT | H | AK | U | L |

| ANSI-Nr. | Pitch p | | Roller width | Roller \varnothing | Pin \varnothing | Inner width | Link plate height | Transverse | Pin length | Overall width | Bearing area | Min. ultimate strength required*) acc. to DIN/ISO | Weight | Pin link | Loose parts | |
|----------------|---------|-------|------------------------|------------------------|------------------------|------------------------|-------------------|------------|------------------------|------------------------|-------------------|--|----------|-----------|-------------|---|
| | inch | mm | b ₁ min. mm | d ₁ max. mm | d ₂ max. mm | b ₂ max. mm | g mm | e mm | a ₁ max. mm | a ₃ max. mm | A cm ² | F _B N | ≈ q kg/m | Typ | U | L |
| 140 - 1 | 1.75 | 44.45 | 25.22 | 25.4 | 12.7 | 37.0 | 40.8 | – | 53.4 | 59.3 | 4.7 | 172 400 | 7.2 | AT | x | x |
| 160 - 1 | 2.00 | 50.8 | 31.55 | 28.58 | 14.27 | 45.0 | 47.8 | – | 63.6 | 68.9 | 6.42 | 226 800 | 10.3 | AT | x | x |
| 180 - 1 | 2.25 | 57.15 | 35.48 | 35.71 | 17.46 | 50.85 | 50 | – | 71.3 | 80.0 | 8.87 | 280 200 | 14.0 | AT | x | x |
| 200 - 1 | 2.50 | 63.5 | 37.85 | 39.68 | 19.84 | 54.7 | 60 | – | 78.0 | 87.5 | 10.85 | 353 800 | 16.8 | AT | x | x |
| 240 - 1 | 3.00 | 76.2 | 47.35 | 47.63 | 23.8 | 67.5 | 70 | – | 94.8 | 106.7 | 16.07 | 510 300 | 25.0 | AS | x | x |

*) Details about the effective higher Rexnord ultimate strengths and fatigue strength values are available upon request.

Roller chains, double-strand ISO 606 / DIN 8188

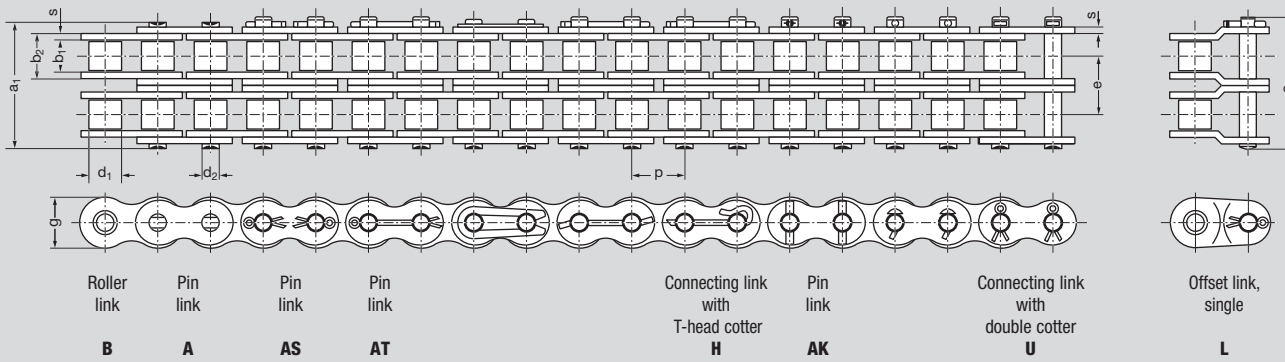

| ANSI-Nr. | Pitch p | | Roller width b_1 min. mm | Roller \varnothing d_1 max. mm | Pin \varnothing d_2 max. mm | Inner width b_2 max. mm | Link plate height g mm | Transverse e mm | Pin length a_1 max. mm | Overall width a_3 max. mm | Bearing area A cm ² | Min. ultimate strength required*) acc. to DIN/ISO F_B N | Weight $\approx q$ kg/m | Pin link | | | Loose parts | | |
|----------|---------|-------|-------------------------------|---------------------------------------|------------------------------------|------------------------------|-----------------------------|----------------------|-----------------------------|--------------------------------|-------------------------------------|---|----------------------------|----------|---|---|-------------|---|---|
| | inch | mm | | | | | | | | | | | | Typ | U | L | U | L | |
| 140 - 2 | 1.75 | 44.45 | 25.22 | 25.40 | 12.70 | 37.0 | 40.8 | 48.87 | 103.3 | 109.6 | 9.40 | 344 800 | 14.2 | AK | x | x | x | x | x |
| 160 - 2 | 2.00 | 50.8 | 31.55 | 28.58 | 14.27 | 45.0 | 47.8 | 58.55 | 122.1 | 130.1 | 12.84 | 453 600 | 19.5 | AK | x | x | x | x | x |
| 180 - 2 | 2.25 | 57.15 | 35.48 | 35.71 | 17.46 | 50.85 | 50 | 65.84 | 136.7 | 145.4 | 17.74 | 560 500 | 27.0 | AK | x | x | x | x | x |
| 200 - 2 | 2.50 | 63.5 | 37.85 | 39.68 | 19.84 | 54.7 | 60 | 71.55 | 149.6 | 159.2 | 21.70 | 707 600 | 32.7 | AT | x | x | x | x | x |
| 240 - 2 | 3.00 | 76.2 | 47.35 | 47.63 | 23.80 | 67.5 | 70 | 87.83 | 182.7 | 194.7 | 32.13 | 1 020 600 | 49.4 | AS | x | x | x | x | x |

Roller chains, triple-strand ISO 606 / DIN 8188

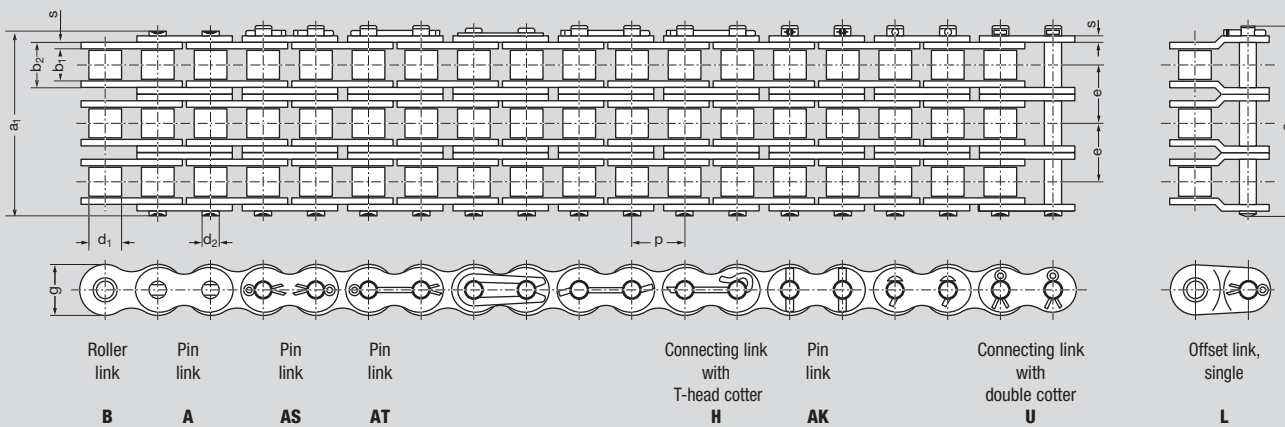

| ANSI-Nr. | Pitch p | | Roller width b_1 min. mm | Roller \varnothing d_1 max. mm | Pin \varnothing d_2 max. mm | Inner width b_2 max. mm | Link plate height g mm | Transverse e mm | Pin length a_1 max. mm | Overall width a_3 max. mm | Bearing area A cm ² | Min. ultimate strength required*) acc. to DIN/ISO F_B N | Weight $\approx q$ kg/m | Pin link | | | Loose parts | | |
|----------|---------|-------|-------------------------------|---------------------------------------|------------------------------------|------------------------------|-----------------------------|----------------------|-----------------------------|--------------------------------|-------------------------------------|---|----------------------------|----------|---|---|-------------|---|---|
| | inch | mm | | | | | | | | | | | | Typ | U | L | U | L | |
| 140 - 3 | 1.75 | 44.45 | 25.22 | 25.40 | 12.70 | 37.0 | 40.8 | 48.87 | 151.2 | 158.5 | 14.10 | 517 200 | 21.5 | AK | x | x | x | x | x |
| 160 - 3 | 2.00 | 50.80 | 31.55 | 28.58 | 14.27 | 45.0 | 47.8 | 58.55 | 180.7 | 188.7 | 19.26 | 680 400 | 26.3 | AK | x | x | x | x | x |
| 180 - 3 | 2.25 | 57.15 | 35.48 | 35.71 | 17.46 | 50.85 | 50 | 65.84 | 202.0 | 210.7 | 26.61 | 840 700 | 40.5 | AK | x | x | x | x | x |
| 200 - 3 | 2.50 | 63.50 | 37.85 | 39.68 | 19.84 | 54.7 | 60 | 71.55 | 221.1 | 230.7 | 32.56 | 1 061 400 | 48.8 | AT | x | x | x | x | x |
| 240 - 3 | 3.00 | 76.20 | 47.35 | 47.63 | 23.80 | 67.5 | 70 | 87.83 | 270.6 | 282.5 | 48.20 | 1 530 900 | 74.1 | AS | x | x | x | x | x |

*) Details about the effective higher Rexnord ultimate strengths and fatigue strength values are available upon request.

Roller chains, American standard, H-series



Small alterations - High fatigue strength.

Links A and B are available for all chains.

Advantages of Rexnord "H" chains

The pins for Rexnord roller chains of the Heavy series, as well as the American standard roller chains, are manufactured from high quality case hardened steel. For both, the surface hardness of ca. 60 HRC guarantees the excellent Rexnord resistance to wear. The link plates however are much thicker. They are taken from the next larger chain pitch.

(see page 42)

Rexnord roller chains in the H (heavy) series have a higher fatigue strength of ca. 40%. The same applies for their permitted loading. The statement that there is no difference in the breaking force between American standard and Heavy series does not affect the above-mentioned 40% higher permitted loading; it is the cross-section of the link plates which determines the fatigue

strength and also the permitted loading.

Chain pins of the ANSI series are not considered as critical when looking at fatigue strength. They only limit the tensile strength.

Generally, tensile strength has no relevance for dynamic loading. It is only significant for static loading conditions for determining static safety factors.

Roller chains, single-strand ISO 606 Heavy series with higher fatigue strength (thicker link plates)

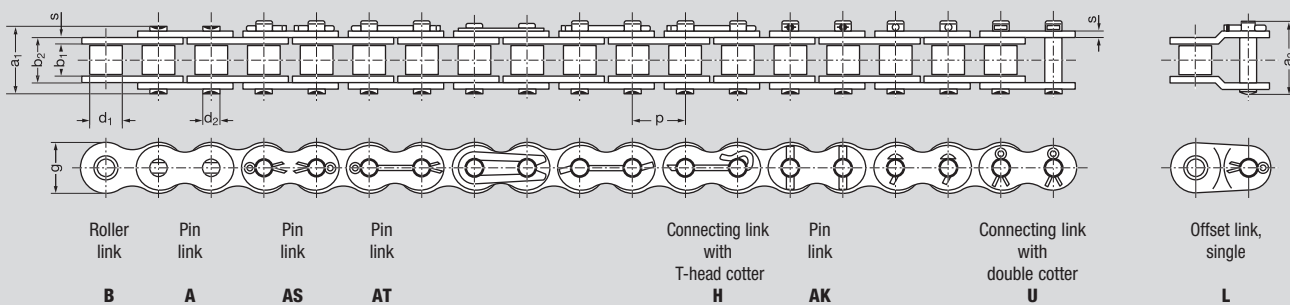

| ANSI-Nr. | Pitch p | | Roller width | Roller \varnothing | Pin \varnothing | Inner width | Link plate thick | Link plate height | Transverse | Pin length | Overall width | Bearing area | Min. ultimate strength required*) acc. to DIN/ISO F_B N | Weight $\approx q$ kg/m | Pin link | | | Loose parts | | | |
|-----------|---------|-------|--------------|----------------------|-------------------|-------------|------------------|-------------------|------------|------------|---------------|--------------|---|-------------------------|---------------|---------------|---------------|---------------|------|------|------|
| | inch | mm | | | | | | | | | | | | | b_1 min. mm | d_1 max. mm | d_2 max. mm | b_2 max. mm | s mm | g mm | e mm |
| 60 H - 1 | 0.75 | 19.05 | 12.57 | 11.91 | 5.94 | 19.35 | 3.05 | 17.7 | - | 28.8 | 32.0 | 1.15 | 31 800 | 1.97 | | x | | x | | | |
| 80 H - 1 | 1.00 | 25.40 | 15.75 | 15.88 | 7.92 | 24.3 | 4.0 | 23.5 | - | 35.9 | 41.0 | 1.94 | 56 700 | 3.2 | | x | | x | | | |
| 100 H - 1 | 1.25 | 31.75 | 18.9 | 19.05 | 9.53 | 29.0 | 4.7 | 29.2 | - | 42.8 | 48.2 | 2.76 | 88 500 | 4.4 | | x | | x | | | |
| 120 H - 1 | 1.50 | 38.10 | 25.22 | 22.23 | 11.10 | 37.0 | 5.5 | 34.4 | - | 53.0 | 59.0 | 4.12 | 127 000 | 6.4 | | x | | x | | | |
| 140 H - 1 | 1.75 | 44.45 | 25.22 | 25.40 | 12.70 | 38.7 | 6.3 | 40.8 | - | 56.6 | 62.6 | 4.91 | 172 400 | 8.3 | AT | x | x | x | | | |
| 160 H - 1 | 2.00 | 50.80 | 31.55 | 28.58 | 14.27 | 46.9 | 7.0 | 47.8 | - | 67.2 | 72.3 | 6.69 | 226 800 | 11.5 | AT | x | x | x | | | |
| 200 H - 1 | 2.50 | 63.50 | 37.85 | 39.68 | 19.84 | 57.6 | 9.5 | 60.0 | - | 84.0 | 93.5 | 11.42 | 353 800 | 20.0 | AT | x | x | x | | | |

*) Details about the effective higher Rexnord ultimate strengths and fatigue strength values are available upon request.

Roller chains, double-strand ISO 606 Heavy series with higher fatigue strength (thicker plates)

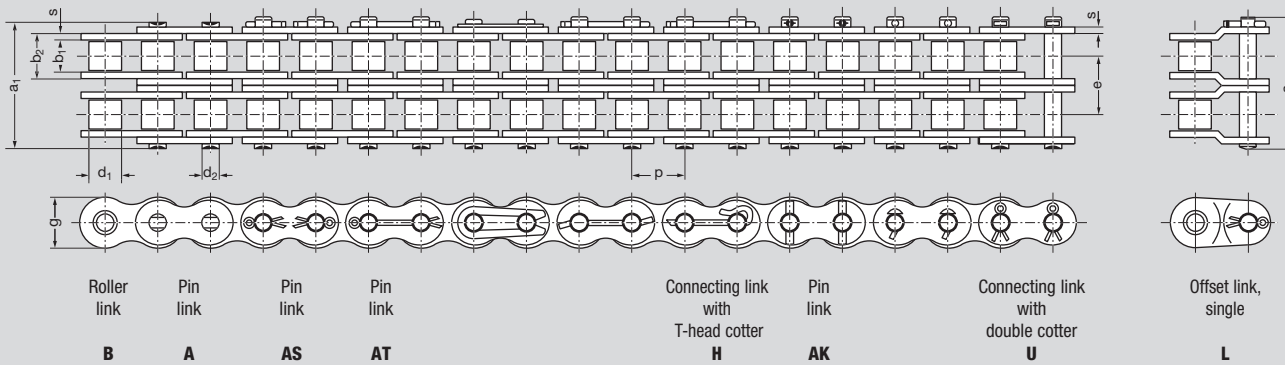

| ANSI-Nr. | Pitch p | | Roller width b ₁ min. mm | Roller Ø d ₁ max. mm | Pin Ø d ₂ max. mm | Inner width b ₂ max. mm | Link plate thick s mm | Link plate height g mm | Transverse e mm | Pin length a ₁ max. mm | Overall width a ₃ max. mm | Bearing area A cm ² | Min. ultimate strength required*) acc. to DINISO F _B N | Weight ≈ q kg/m | Pin link | | | Loose parts | | | |
|-----------|---------|-------|--|------------------------------------|---------------------------------|---------------------------------------|--------------------------|---------------------------|--------------------|--------------------------------------|---|-----------------------------------|---|--------------------|----------|----|---|-------------|---|--|--|
| | inch | mm | | | | | | | | | | | | | Typ | S | U | L | | | |
| 60 H - 2 | 0.75 | 19.05 | 12.57 | 11.91 | 5.94 | 19.35 | 3.05 | 17.7 | 26.10 | 54.9 | 58.0 | 2.30 | 63 600 | 3.95 | | x | | x | | | |
| 80 H - 2 | 1.00 | 25.40 | 15.75 | 15.88 | 7.92 | 24.3 | 4.0 | 23.5 | 32.60 | 68.6 | 73.7 | 3.88 | 113 400 | 6.3 | | x | | x | | | |
| 100 H - 2 | 1.25 | 31.75 | 18.90 | 19.05 | 9.53 | 29.0 | 4.7 | 29.2 | 39.12 | 82.0 | 97.8 | 5.52 | 177 000 | 9.0 | | x | | x | | | |
| 120 H - 2 | 1.50 | 38.10 | 25.22 | 22.23 | 11.10 | 37.0 | 5.5 | 34.4 | 48.91 | 101.8 | 109.5 | 8.36 | 254 000 | 12.6 | | x | | x | | | |
| 140 H - 2 | 1.75 | 44.45 | 25.22 | 25.40 | 12.70 | 38.7 | 6.3 | 40.8 | 52.20 | 108.7 | 116.0 | 9.82 | 344 800 | 16.2 | | AK | x | x | x | | |
| 160 H - 2 | 2.00 | 50.80 | 31.55 | 28.58 | 14.27 | 46.9 | 7.0 | 47.8 | 61.89 | 128.6 | 136.8 | 13.40 | 453 600 | 22.0 | | AK | x | x | x | | |
| 200 H - 2 | 2.50 | 63.50 | 37.85 | 39.68 | 19.84 | 57.6 | 9.5 | 60.0 | 78.30 | 161.6 | 171.2 | 22.84 | 707 600 | 39.0 | | AT | x | x | x | | |

Roller chains, triple-strand ISO 606 Heavy series with higher fatigue strength (thicker plates)

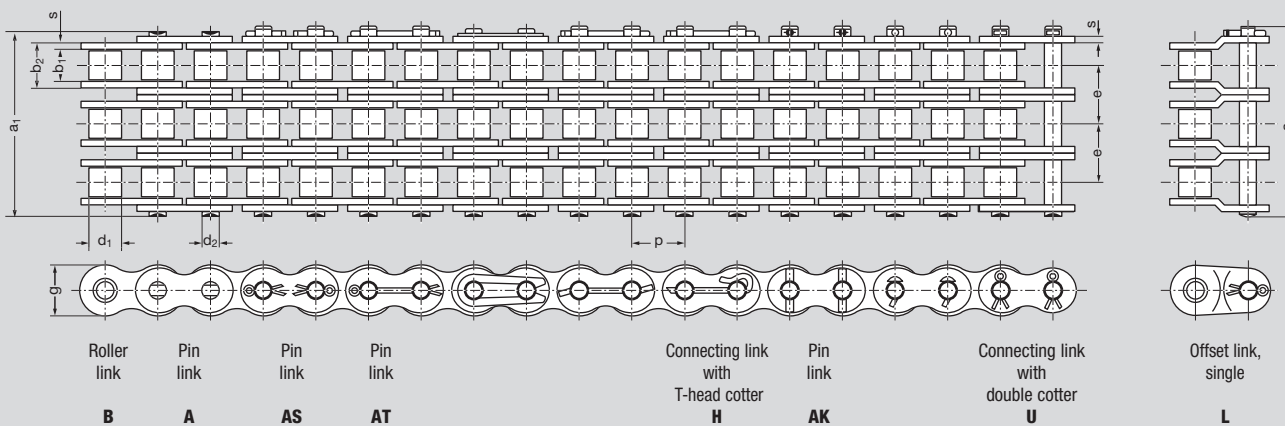

| ANSI-Nr. | Pitch p | | Roller width b ₁ min. mm | Roller Ø d ₁ max. mm | Pin Ø d ₂ max. mm | Inner width b ₂ max. mm | Link plate thick s mm | Link plate height g mm | Transverse e mm | Pin length a ₁ max. mm | Overall width a ₃ max. mm | Bearing area A cm ² | Min. ultimate strength required*) acc. to DINISO F _B N | Weight ≈ q kg/m | Pin link | | | Loose parts | | | |
|-----------|---------|-------|--|------------------------------------|---------------------------------|---------------------------------------|--------------------------|---------------------------|--------------------|--------------------------------------|---|-----------------------------------|---|--------------------|----------|----|---|-------------|---|--|--|
| | inch | mm | | | | | | | | | | | | | Typ | S | U | L | | | |
| 60 H - 3 | 0.75 | 19.05 | 12.57 | 11.91 | 5.94 | 19.35 | 3.05 | 17.7 | 26.10 | 81.1 | 84.4 | 3.45 | 95 400 | 5.8 | | x | | x | | | |
| 80 H - 3 | 1.00 | 25.40 | 15.75 | 15.88 | 7.92 | 24.3 | 4.0 | 23.5 | 32.60 | 101.2 | 106.3 | 5.82 | 170 100 | 9.6 | | x | | x | | | |
| 100 H - 3 | 1.25 | 31.75 | 18.90 | 19.05 | 9.53 | 29.0 | 4.7 | 29.2 | 39.12 | 120.0 | 126.6 | 8.30 | 265 500 | 13.4 | | x | | x | | | |
| 120 H - 3 | 1.50 | 38.10 | 25.22 | 22.23 | 11.10 | 37.0 | 5.5 | 34.4 | 48.91 | 150.8 | 158.7 | 12.35 | 381 000 | 19.5 | | x | | x | | | |
| 140 H - 3 | 1.75 | 44.45 | 25.22 | 25.40 | 12.70 | 38.7 | 6.3 | 40.8 | 52.20 | 160.9 | 168.3 | 14.30 | 517 200 | 24.7 | | AK | x | x | x | | |
| 160 H - 3 | 2.00 | 50.80 | 31.55 | 28.58 | 14.27 | 46.9 | 7.0 | 47.8 | 61.89 | 198.0 | 198.7 | 20.10 | 680 400 | 29.4 | | AK | x | x | x | | |
| 200 H - 3 | 2.50 | 63.50 | 37.85 | 39.68 | 19.84 | 57.6 | 9.5 | 60.0 | 78.30 | 239.1 | 248.7 | 34.26 | 1 061 400 | 58.0 | | AT | x | x | x | | |

*) Details about the effective higher Rexnord ultimate strengths and fatigue strength values are available upon request.

Roller chains, American standard, HE series



Extremely high shock-resistance.

Links A and B are available for all chains.

Advantages of Rexnord "HE" chains

Link plates in the Rexnord roller chain HE series make use of the next largest plate dimension, giving them ca. 40 % more loading capacity (fatigue strength) in comparison to the standard series. Another difference from standard and H series chains is that the pins used are from through-hardened material. They are fully-hardened and their higher shearing strength and tensile strength improve the

ultimate strength and shock-resistance characteristics.

Pins from through-hardened material do not possess the same high surface hardness as case-hardened pins of the standard and Heavy series. The result is a slightly lower resistance to wear.

In cases where high demands are made on the resistance to wear and there is not enough lubrication, then additional induc-

tive surface hardening of the pin should be considered.

The surface hardness will be increased above 60 HRc and thereby - in addition to the high fatigue strength and shock-resistance - an exceptionally high resistance to wear will be achieved.

Nominal values for link plate thicknesses are shown. Exact dimensions and tolerances can be provided upon request.

Roller chains, single-strand ISO 606 Heavy series with higher fatigue strength (thicker plates) and higher tensile strength

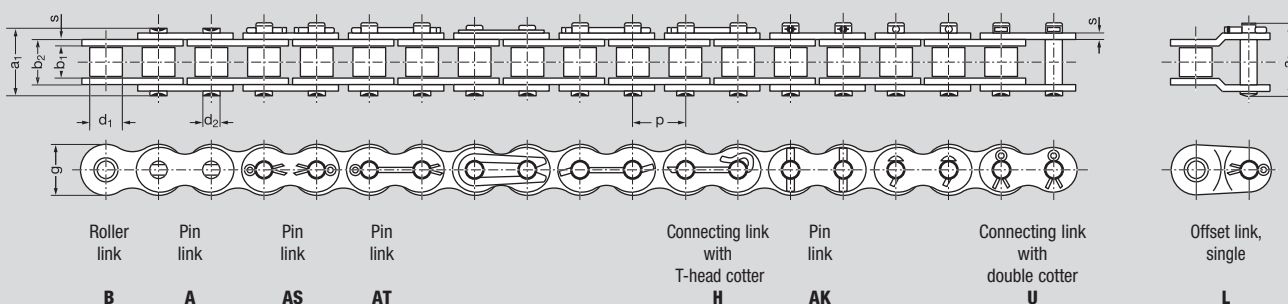

Roller link **B** Pin link **A** Pin link **AS** Pin link **AT** Connecting link with T-head cotter **H** Pin link **AK** Connecting link with double cotter **U** Offset link, single **L**

| ANSI-Nr. | Pitch p | | Roller width | Roller \varnothing | Pin \varnothing | Inner width | Link plate thick | Link plate height | Transverse | Pin length | Overall width | Bearing area | Min. ultimate strength required*) acc. to DIN/ISO F_B N | Weight $\approx q$ kg/m | Pin link | | | Loose parts | | | |
|------------|---------|-------|--------------|----------------------|-------------------|-------------|------------------|-------------------|------------|------------|---------------|--------------|---|-------------------------|---------------|---------------|---------------|---------------|------|------|------|
| | inch | mm | | | | | | | | | | | | | b_1 min. mm | d_1 max. mm | d_2 max. mm | b_2 max. mm | s mm | g mm | e mm |
| 60 HE - 1 | 0.75 | 19.05 | 12.57 | 11.91 | 5.94 | 19.35 | 3.05 | 17.7 | - | 28.8 | 32.0 | 1.15 | 42 000 | 1.97 | | x | | x | | | |
| 80 HE - 1 | 1.00 | 25.40 | 15.75 | 15.88 | 7.92 | 24.3 | 4.0 | 23.3 | - | 35.9 | 41.0 | 1.94 | 75 600 | 3.2 | | x | | x | | | |
| 100 HE - 1 | 1.25 | 31.75 | 18.90 | 19.05 | 9.53 | 29.0 | 4.7 | 29.2 | - | 42.8 | 48.2 | 2.76 | 113 400 | 4.4 | | x | | x | | | |
| 120 HE - 1 | 1.50 | 38.10 | 25.22 | 22.23 | 11.10 | 37.0 | 5.5 | 34.4 | - | 53.0 | 59.0 | 4.10 | 155 700 | 6.4 | | x | | x | | | |
| 140 HE - 1 | 1.75 | 44.45 | 25.22 | 25.40 | 12.70 | 38.7 | 6.3 | 40.8 | - | 56.6 | 62.6 | 4.94 | 209 100 | 8.3 | AT | x | x | x | | | |
| 160 HE - 1 | 2.00 | 50.80 | 31.55 | 28.58 | 14.27 | 46.9 | 7.0 | 47.8 | - | 67.2 | 72.3 | 6.69 | 266 900 | 11.8 | AT | x | x | x | | | |
| 200 HE - 1 | 2.50 | 63.50 | 37.85 | 39.68 | 19.84 | 57.6 | 9.5 | 60.0 | - | 84.0 | 93.5 | 11.42 | 405 000 | 20.0 | AT | x | x | x | | | |

*) Details about the effective higher Rexnord ultimate strengths and fatigue strength values are available upon request.

Roller chains, double-strand ISO 606

Heavy series with higher fatigue strength (thicker plates) and higher tensile strength

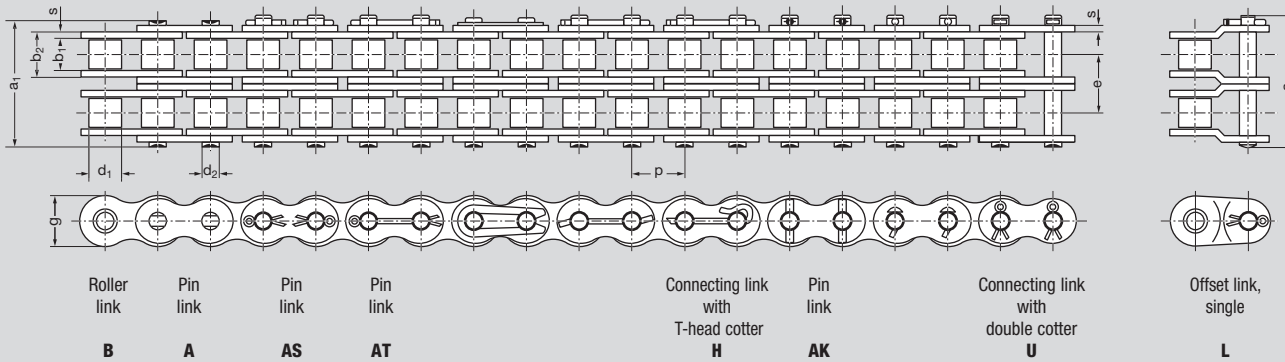

| ANSI-Nr. | Pitch p | | Roller width b ₁ min. mm | Roller Ø d ₁ max. mm | Pin Ø d ₂ max. mm | Inner width b ₂ max. mm | Link plate thick s mm | Link plate height g mm | Transverse e mm | Pin length a ₁ max. mm | Overall width a ₃ max. mm | Bearing area A cm ² | Min. ultimate strength required*) acc. to DINISO F _B N | Weight ≈ q kg/m | Pin link | | | Loose parts | | | |
|------------|---------|-------|--|------------------------------------|---------------------------------|---------------------------------------|--------------------------|---------------------------|--------------------|--------------------------------------|---|-----------------------------------|---|--------------------|----------|---|---|-------------|--|--|--|
| | inch | mm | | | | | | | | | | | | | Typ | S | U | L | | | |
| 80 HE - 2 | 1.00 | 25.40 | 15.75 | 15.88 | 7.92 | 24.3 | 4.0 | 23.5 | 32.6 | 68.6 | 73.7 | 3.88 | 151 200 | 5.3 | | x | | x | | | |
| 100 HE - 2 | 1.25 | 31.75 | 18.90 | 19.05 | 9.53 | 29.0 | 4.7 | 29.2 | 39.12 | 82.0 | 87.8 | 5.52 | 226 800 | 9.0 | | x | | x | | | |
| 120 HE - 2 | 1.50 | 38.10 | 25.22 | 22.23 | 11.10 | 37.0 | 5.5 | 34.4 | 48.91 | 101.8 | 109.5 | 8.36 | 311 400 | 12.6 | | x | | x | | | |
| 140 HE - 2 | 1.75 | 44.45 | 25.22 | 25.40 | 12.70 | 38.7 | 6.3 | 40.8 | 52.20 | 108.7 | 116.0 | 9.82 | 418 200 | 15.8 | AK | x | x | x | | | |
| 160 HE - 2 | 2.00 | 50.80 | 31.55 | 28.58 | 14.27 | 46.9 | 7.0 | 47.8 | 61.89 | 128.6 | 136.8 | 13.40 | 533 800 | 22.0 | AK | x | x | x | | | |
| 200 HE - 2 | 2.50 | 63.50 | 37.85 | 39.68 | 19.84 | 57.6 | 9.5 | 60.0 | 78.30 | 161.6 | 171.2 | 22.84 | 810 000 | 39.0 | AT | x | x | x | | | |

Roller chains, triple-strand ISO 606

Heavy series with higher fatigue strength (thicker plates) and higher tensile strength

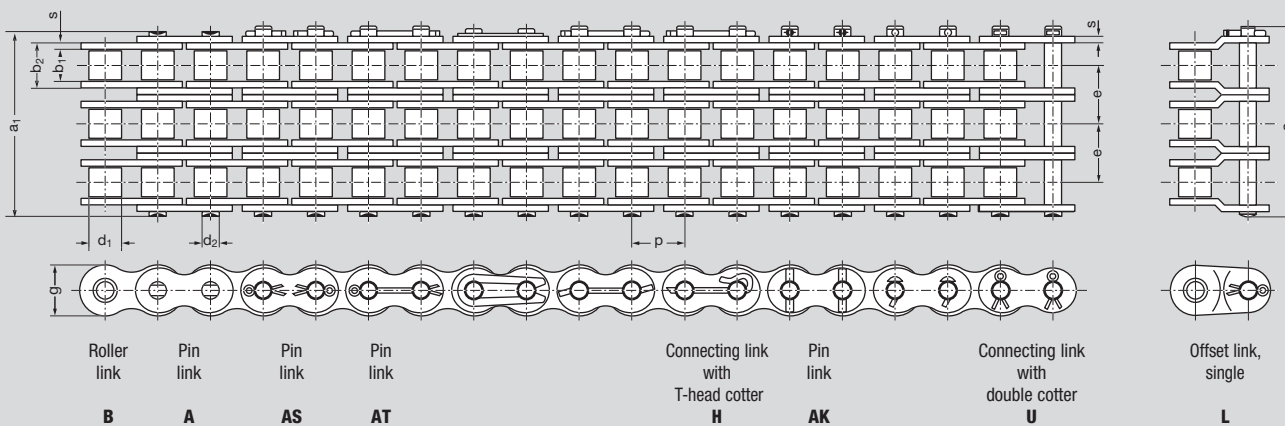

| ANSI-Nr. | Pitch p | | Roller width b ₁ min. mm | Roller Ø d ₁ max. mm | Pin Ø d ₂ max. mm | Inner width b ₂ max. mm | Link plate thick s mm | Link plate height g mm | Transverse e mm | Pin length a ₁ max. mm | Overall width a ₃ max. mm | Bearing area A cm ² | Min. ultimate strength required*) acc. to DINISO F _B N | Weight ≈ q kg/m | Pin link | | | Loose parts | | | |
|------------|---------|-------|--|------------------------------------|---------------------------------|---------------------------------------|--------------------------|---------------------------|--------------------|--------------------------------------|---|-----------------------------------|---|--------------------|----------|---|---|-------------|--|--|--|
| | inch | mm | | | | | | | | | | | | | Typ | S | U | L | | | |
| 80 HE - 3 | 1.00 | 25.40 | 15.75 | 15.88 | 7.92 | 24.3 | 4.0 | 23.5 | 32.60 | 101.2 | 106.3 | 5.82 | 226 800 | 9.6 | | x | | x | | | |
| 100 HE - 3 | 1.25 | 31.75 | 18.90 | 19.05 | 9.53 | 29.0 | 4.7 | 29.2 | 39.12 | 120.0 | 126.6 | 8.30 | 340 200 | 13.4 | | x | | x | | | |
| 120 HE - 3 | 1.50 | 38.10 | 25.22 | 22.23 | 11.10 | 37.0 | 5.5 | 34.4 | 48.91 | 150.8 | 158.7 | 12.35 | 467 100 | 18.5 | | x | | x | | | |
| 140 HE - 3 | 1.75 | 44.45 | 25.22 | 25.40 | 12.70 | 38.7 | 6.3 | 40.8 | 52.20 | 160.9 | 168.3 | 14.30 | 627 300 | 24.7 | AK | x | x | x | | | |
| 160 HE - 3 | 2.00 | 50.80 | 31.55 | 28.58 | 14.27 | 46.9 | 7.0 | 47.8 | 61.89 | 198.0 | 198.7 | 20.10 | 800 700 | 29.4 | AK | x | x | x | | | |
| 200 HE - 3 | 2.50 | 63.50 | 37.85 | 39.68 | 19.84 | 57.6 | 9.5 | 60.0 | 78.30 | 239.1 | 248.7 | 34.26 | 1215 000 | 58.0 | AT | x | x | x | | | |

*) Details about the effective higher Rexnord ultimate strengths and fatigue strength values are available upon request.

Roller chains, Industry standard



Industry standard chains - for individual demands.

Links A and B are available for all chains.
All roller chains, even with straight link plates, are available as multiplex chains.

- 1) Bushes- \emptyset
 - He 488 = Bushed chain.
 - Higher inner plate „g“ = higher fatigue strength.
 - ▲ also as duplex and driplex chain available

Connecting link with wire

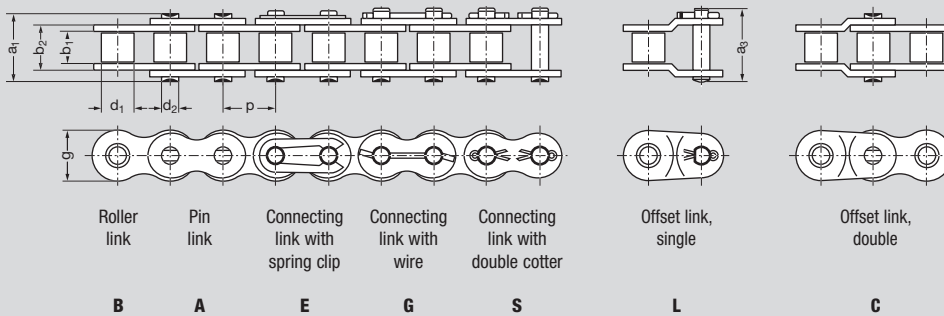

| Chain No. | Pitch p | | Roller width b ₁ min. mm | Roller \emptyset d ₁ max. mm | Pin \emptyset d ₂ max. mm | Inner width b ₂ max. mm | Link plate height g mm | Transverse e mm | Pin length a ₁ max. mm | Overall width a ₃ max. mm | Bearing area A cm ² | Min. ultimate strength *) F _B N | Weight \approx q kg/m | Loose parts | | | |
|-----------|---------|--------|--|--|---|---------------------------------------|---------------------------|--------------------|--------------------------------------|---|-----------------------------------|---|----------------------------|-------------|---|---|---|
| | inch | mm | | | | | | | | | | | | S | C | E | L |
| Re 217 | 0.50 | 12.7 | 6.4 | 8.51 | 4.45 | 9.93 | 11.6 | — | 15.4 | 18.9 | 0.44 | 18 000 | 0.67 | | x | x | x |
| Re 317 | 0.625 | 15.875 | 6.48 | 10.16 | 5.08 | 10.08 | 14.7 | — | 16.0 | 20.0 | 0.51 | 23 600 | 0.80 | | x | x | x |
| Re 425 | 0.75 | 19.05 | 13.5 | 12.07 | 5.72 | 19.40 | 16.8 | — | 27.0 | 31.8 | 1.12 | 33 500 | 1.57 | x | x | x | x |
| Re 480 | 0.75 | 19.05 | 11.68 | 12.07 | 6.10 | 17.23 | 16.8 | — | 25.0 | 29.5 | 1.05 | 40 000 | 1.45 | G | x | x | x |
| Re 487 | 0.787 | 20.0 | 16.0 | 12.00 | 6.00 | 22.50 | 19.0 | — | 32.1 | 35.9 | 1.35 | 35 500 | 2.00 | x | G | x | x |
| He 488 | 0.787 | 20.0 | 16.0 | 12.00 ¹⁾ | 8.00 | 22.50 | 19.0 | — | 32.5 | 37.3 | 1.80 | 35 500 | 2.00 | x | x | x | x |
| Re 514 | 1.00 | 25.4 | 12.7 | 14.00 | 7.00 | 19.07 | 19.7 | — | 27.3 | 33.1 | 1.33 | 45 000 | 1.74 | x | x | x | x |
| Re 516 | 1.00 | 25.4 | 12.7 ¹⁾ | 15.88 | 8.28 | 21.07 | 20.6 | — | 30.8 | 37.6 | 1.74 | 63 000 | 2.40 | x | x | x | x |
| Re 519 | 1.00 | 25.4 | 17.02 | 15.88 | 9.00 | 25.40 | 24.1 | — | 36.0 | 39.8 | 2.29 | 80 000 | 3.16 | x | x | G | |
| Rz 519 | 1.00 | 25.4 | 17.02 | 15.88 | 9.00 | 25.40 | 24.1 | 31.88 | 67.8 | 72.0 | 4.58 | 160 000 | 6.25 | x | x | G | |
| Re 525 | 1.00 | 25.4 | 12.7 | 12.70 | 7.00 | 19.07 | 20.8 | — | 27.4 | 32.5 | 1.33 | 45 000 | 1.59 | x | x | x | x |
| Re 626 | 1.18 | 30.0 | 17.02 | 15.88 | 8.28 | 25.40 | 20.5 | — | 35.5 | 41.9 | 2.10 | 63 000 | 2.33 | x | x | | x |

*) Details about the effective higher Rexnord ultimate strengths and fatigue strength values are available upon request.

Roller chains for heavy drives and lifting applications

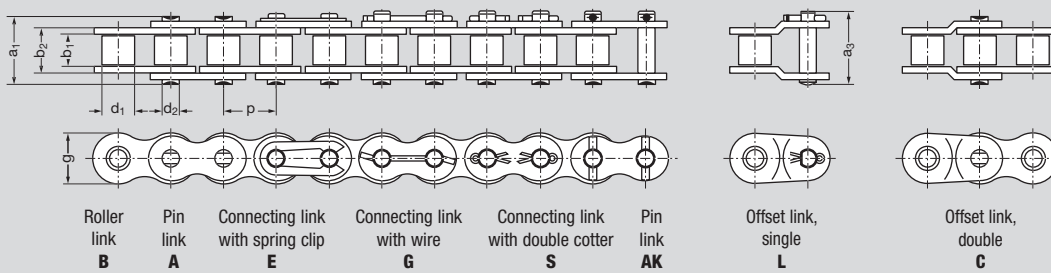

| Chain No. | Pitch p | | Roller width b ₁ min. mm | Roller Ø d ₁ max. mm | Pin Ø d ₂ max. mm | Inner width b ₂ max. mm | Link plate height g mm | Pin length a ₁ max. mm | Overall width a ₃ max. mm | Bearing area A cm ² | Min. ultimate strength *) F _B N | Weight ≈ q kg/m | Loose parts | | | |
|------------------|---------|-------|--|------------------------------------|---------------------------------|---------------------------------------|---------------------------|--------------------------------------|---|-----------------------------------|---|--------------------|-------------|---|---|---|
| | inch | mm | | | | | | | | | | | S | C | E | L |
| KRV 12 | 1,00 | 25,40 | 12,70 | 19,05 | 10,19 | 25,7 | 24,0 | 40,1 | – | 2,61 | 117 500 | 4,40 | x | | | |
| ▲ R 38 SH | 1,50 | 38,10 | 25,40 | 25,40 | 14,63 | 40,0 | 37,2 | 56,7 | – | 5,85 | 235 000 | 7,80 | x | | | |
| ▲ R 44 SH | 1,75 | 44,45 | 30,99 | 27,94 | 15,90 | 46,5 | 40,8 | 66,3 | – | 7,39 | 270 000 | 9,80 | x | | | |

Hoisting chains for straddle carriers

| Chain No. | Pitch p | | Roller width b ₁ min. mm | Roller Ø d ₁ max. mm | Pin Ø d ₂ max. mm | Inner width b ₂ max. mm | Link plate height g mm | Pin length a ₁ max. mm | Overall width a ₃ max. mm | Bearing area A cm ² | Min. ultimate strength *) F _B N | Weight ≈ q kg/m | Loose parts | | | |
|-------------------|---------|------|--|------------------------------------|---------------------------------|---------------------------------------|---------------------------|--------------------------------------|---|-----------------------------------|---|--------------------|-------------|---|---|----|
| | inch | mm | | | | | | | | | | | S | C | E | AK |
| ○ 64 S – 1 | 2,50 | 63,5 | 38,1 | 39,38 | 22,45 | 57,9 | 59,5 | 84,4 | 93,9 | 13,2 | 530 000 | 16,50 | 1 | | | x |
| ○ 200 HF | 2,50 | 63,5 | 38,1 | 39,68 | 19,80 | 54,9 | 59,5 | – | 85,6 | 10,9 | 353 800 | 17,00 | x | | | |

Roller chains with straight link plates, ISO 606 / DIN 8187

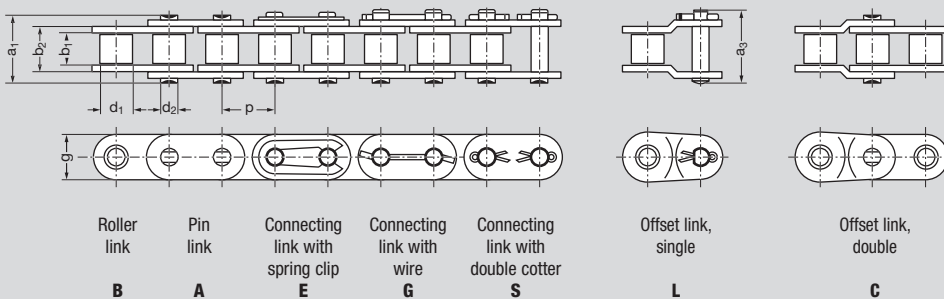

| Chain No. | Pitch p | | Roller width b ₁ min. mm | Roller Ø d ₁ max. mm | Pin Ø d ₂ max. mm | Inner width b ₂ max. mm | Link plate height g mm | Transverse e mm | Pin length a ₁ max. mm | Overall width a ₃ max. mm | Bearing area A cm ² | Min. ultimate strength required*) acc. to DIN ISO F _B N | Weight ≈ q kg/m | Loose parts | | | |
|----------------------|---------|--------|--|------------------------------------|---------------------------------|---------------------------------------|---------------------------|--------------------|--------------------------------------|---|-----------------------------------|--|--------------------|-------------|---|---|---|
| | inch | mm | | | | | | | | | | | | S | C | E | L |
| ○ 06 B – 1 GL | 0,375 | 9,525 | 5,72 | 6,35 | 3,28 | 8,53 | 8,2 | – | 13,5 | 16,8 | 0,28 | 9 000 | 0,42 | | | x | |
| ○ 06 B – 2 GL | 0,375 | 9,525 | 5,72 | 6,35 | 3,28 | 8,53 | 8,2 | 10,24 | 23,8 | 27,1 | 0,56 | 16 900 | 0,78 | | | x | |
| 06 B – 3 GL | 0,375 | 9,525 | 5,72 | 6,35 | 3,28 | 8,53 | 8,2 | 10,24 | 34,0 | 37,3 | 0,84 | 24 900 | 1,18 | x | x | x | |
| 06 B – 3 | 0,375 | 9,525 | 5,72 | 6,35 | 3,28 | 8,53 | 8,2 | 10,24 | 34,0 | 37,3 | 0,84 | 24 900 | 1,18 | x | x | x | |
| 08 B – 1 GL | 0,50 | 12,70 | 7,75 | 8,51 | 4,45 | 11,3 | 12,0 | – | 17,0 | 19,0 | 0,50 | 18 000 | 0,75 | | | x | |
| 10 B – 1 GL | 0,625 | 15,875 | 9,65 | 10,16 | 5,08 | 13,28 | 13,8 | – | 18,9 | 22,0 | 0,67 | 22 400 | 1,00 | | | x | |
| 10 B – 2 GL | 0,625 | 15,875 | 9,65 | 10,16 | 5,08 | 13,28 | 13,8 | 16,59 | 35,5 | 38,6 | 1,34 | 44 500 | 1,90 | | | x | |
| 12 B – 1 GL | 0,75 | 19,05 | 11,68 | 12,07 | 5,72 | 15,62 | 15,9 | – | 22,3 | 25,1 | 0,89 | 29 000 | 1,33 | | | x | |
| 12 B – 2 GL | 0,75 | 19,05 | 11,68 | 12,07 | 5,72 | 15,62 | 15,9 | 19,46 | 41,7 | 44,4 | 1,79 | 57 800 | 2,60 | | | x | |
| 16 B – 1 GL | 1,00 | 25,40 | 17,02 | 15,88 | 8,28 | 25,4 | 20,5 | – | 35,4 | 42,4 | 2,10 | 60 000 | 2,85 | x | | x | |
| 16 B – 2 GL | 1,00 | 25,40 | 17,02 | 15,88 | 8,28 | 25,4 | 20,5 | 31,88 | 67,4 | 74,0 | 4,21 | 106 000 | 5,80 | x | | x | |
| 20 B – 1 GL | 1,25 | 31,75 | 19,56 | 19,05 | 10,19 | 29,0 | 25,8 | – | 40,4 | 47,6 | 2,96 | 95 000 | 4,00 | x | | | |
| 24 B – 1 GL | 1,50 | 38,10 | 25,40 | 25,40 | 14,63 | 37,9 | 33,0 | – | 53,8 | 60,6 | 5,54 | 160 000 | 7,50 | x | | | |
| 32 B – 1 GL | 2,00 | 50,80 | 30,80 | 29,21 | 17,81 | 45,5 | 41,2 | – | 65,1 | 73,6 | 8,10 | 250 000 | 10,40 | x | | | |
| 60 – 1 GL | 0,75 | 19,05 | 12,57 | 11,91 | 5,94 | 17,7 | 17,7 | – | 25,7 | 29,6 | 1,05 | 31 800 | 1,65 | x | | x | |
| 80 – 1 GL | 1,00 | 25,4 | 15,75 | 15,88 | 7,92 | 22,5 | 24,0 | – | 32,9 | 38,0 | 1,78 | 56 700 | 3,00 | x | | x | |

*) Details about the effective higher Rexnord ultimate strengths and fatigue strength values are available upon request.

RexCarbon - roller chains



Maintenance-free drives.

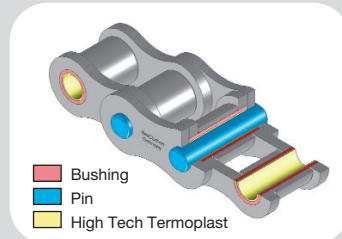

Links A and B are available for all chains.
Carbon chain also as duplex and driplex chain available.
 Carbon chain length tolerance: 0 up to +0,35 %.
See also in the Rexnord Expertise Leaflet.

RexCarbon roller chain, single-strand acc. to European standard (DIN 8187)

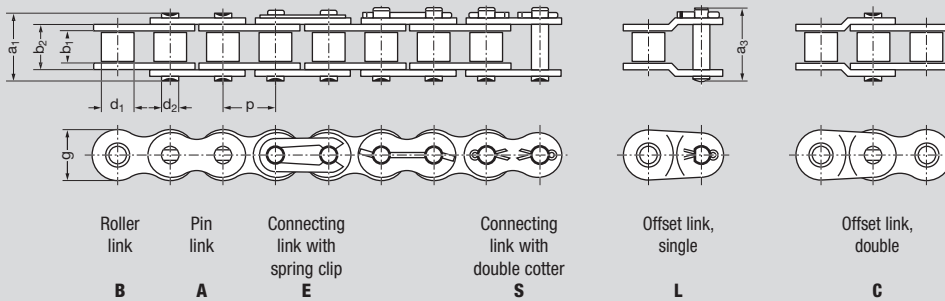

| Chain No. | Pitch p | | Roller width | Roller \varnothing | Pin \varnothing | Inner width | Link plate height | Transverse | Pin length | Overall width | Bearing area | Min. ultimate strength required*) acc. to DIN/ISO | Weight | Loose parts | | | |
|-------------|---------|--------|------------------------|------------------------|------------------------|------------------------|-------------------|------------|------------------------|------------------------|-------------------|---|----------|-------------|---|---|---|
| | inch | mm | b ₁ min. mm | d ₁ max. mm | d ₂ max. mm | b ₂ max. mm | g mm | e mm | a ₁ max. mm | a ₃ max. mm | A cm ² | F _B N | ≈ q kg/m | S | C | E | L |
| 08 B - 1 CB | 0.50 | 12.70 | 7.75 | 8.51 | 4.45 | 11.30 | 11.6 | - | 16.7 | 18.2 | 0.50 | 18 000 | 0.68 | | x | x | x |
| 10 B - 1 CB | 0.625 | 15.875 | 9.65 | 10.16 | 5.08 | 13.28 | 14.6 | - | 18.9 | 20.5 | 0.67 | 22 400 | 0.87 | | x | x | x |
| 12 B - 1 CB | 0.75 | 19.05 | 11.68 | 12.07 | 5.72 | 15.62 | 15.9 | - | 22.3 | 23.5 | 0.89 | 29 000 | 1.15 | x | x | x | x |
| 16 B - 1 CB | 1.00 | 25.40 | 17.02 | 15.88 | 8.28 | 25.40 | 20.5 | - | 35.4 | 37.6 | 2.10 | 60 000 | 2.60 | x | x | x | x |

RexCarbon roller chain, double-strand acc. to European standard (DIN 8187)

| Chain No. | Pitch p | | Roller width | Roller \varnothing | Pin \varnothing | Inner width | Link plate height | Transverse | Pin length | Overall width | Bearing area | Min. ultimate strength required*) acc. to DIN/ISO | Weight | Loose parts | | | |
|-------------|---------|--------|------------------------|------------------------|------------------------|------------------------|-------------------|------------|------------------------|------------------------|-------------------|---|----------|-------------|---|---|---|
| | inch | mm | b ₁ min. mm | d ₁ max. mm | d ₂ max. mm | b ₂ max. mm | g mm | e mm | a ₁ max. mm | a ₃ max. mm | A cm ² | F _B N | ≈ q kg/m | S | C | E | L |
| 08 B - 2 CB | 0.50 | 12.70 | 7.75 | 8.51 | 4.45 | 11.30 | 11.6 | - | 31.0 | 32.2 | 1.01 | 32 000 | 1.26 | | x | x | x |
| 10 B - 2 CB | 0.625 | 15.875 | 9.65 | 10.16 | 5.08 | 13.28 | 14.6 | - | 35.5 | 37.2 | 1.34 | 44 500 | 1.73 | | x | x | x |
| 12 B - 2 CB | 0.75 | 19.05 | 11.68 | 12.07 | 5.72 | 15.62 | 15.9 | - | 41.7 | 43.0 | 1.79 | 51 800 | 2.27 | | x | x | x |
| 16 B - 2 CB | 1.00 | 25.40 | 17.02 | 15.88 | 8.28 | 25.40 | 20.5 | - | 67.1 | 69.5 | 4.21 | 106 000 | 4.50 | | x | x | x |

*) Details about the effective higher Rexnord ultimate strengths and fatigue strength values are available upon request.

Hollow pin chains



Flexible transportation, connecting and joining.

Type A as bush chain

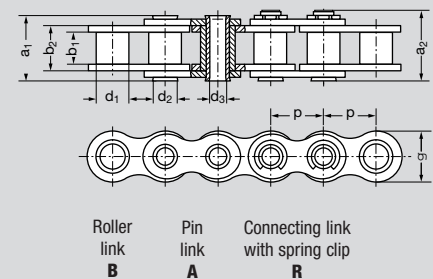

Type B as roller chain

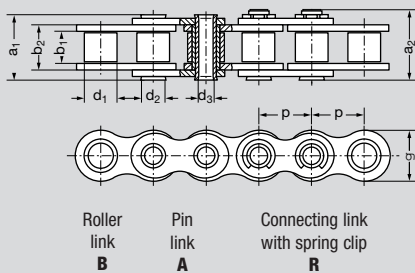

Type C with carrier rollers

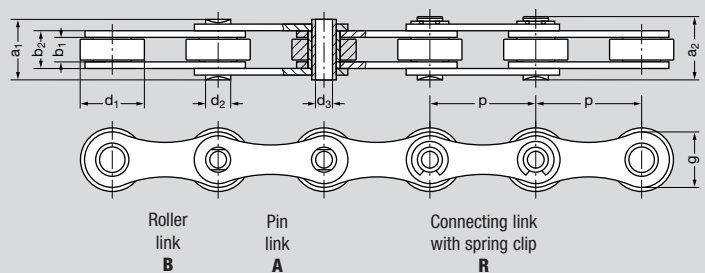

Hollow pin chains, single-strand, main dimensions acc. to European and American standard

| Chain No. | Type | Pitch p | | Roller width | | Roller Ø | | Pin Ø | | Hollow pin chains inner Ø | Roller link width | Link plate height g | Transverse e | Pin length a ₁ | Overall width a ₂ | Bearing area A | Min. ultimate strength required*) acc. to DIN/ISO F _B N | Weight ≈ q kg/m | Loose parts | |
|-------------|------|---------|--------|------------------------|------------------------|------------------------|------------------------|------------------------|------|---------------------------|-------------------|---------------------|--------------|---------------------------|------------------------------|----------------|--|-----------------|-------------|--|
| | | inch | mm | b ₁ min. mm | d ₁ max. mm | d ₂ max. mm | d ₃ min. mm | b ₂ max. mm | C | | | | | | | | | | R | |
| 10 B – 1 HB | B | 0.625 | 15.875 | 9.65 | 10.16 | 5.94 | 4 | 13.9 | 14.7 | – | 19.3 | 21.1 | 1.14 | 17 000 | 0.80 | | | | | |
| 12 B – 1 HB | B | 0.75 | 19.05 | 11.68 | 12.07 | 6.50 | 4 | 16.3 | 15.9 | – | 22.4 | 24.0 | 1.06 | 21 000 | 1.10 | | | | | |
| 40 – 1 HB | A | 0.50 | 12.70 | 7.85 | 7.95 ¹⁾ | 5.72 | 4 | 11.9 | 11.6 | – | 17.1 | 18.5 | 0.68 | 10 000 | 0.53 | | | | | |
| 60 – 1 HB | B | 0.75 | 19.05 | 12.57 | 11.91 | 7.00 | 5 | 18.65 | 17.7 | – | 26.3 | 27.2 | 1.30 | 20 000 | 1.32 | | | | | |
| 80 – 1 HB | A | 1.00 | 25.40 | 15.75 | 15.88 ¹⁾ | 11.67 | 8.1 | 22.5 | 23.7 | – | 32.6 | 33.7 | 2.63 | 53 000 | 2.40 | | | | | |
| SK 845 | C | 2.00 | 50.80 | 10.00 | 30.00 | 11.60 | 8.1 | 16.8 | 25.6 | – | 26.4 | 28.6 | 1.95 | 50 000 | 2.06 | | | | | |

Hollow pin chains, double-strand, main dimensions acc. to European standard

| Chain No. | Type | Pitch p | | Roller width | | Roller Ø | | Pin Ø | | Hollow pin chains inner Ø | Roller link width | Link plate height g | Transverse e | Pin length a ₁ | Overall width a ₂ | Bearing area A | Min. ultimate strength required*) acc. to DIN/ISO F _B N | Weight ≈ q kg/m | Loose parts | |
|-------------|------|---------|--------|------------------------|------------------------|------------------------|------------------------|------------------------|------|---------------------------|-------------------|---------------------|--------------|---------------------------|------------------------------|----------------|--|-----------------|-------------|--|
| | | inch | mm | b ₁ min. mm | d ₁ max. mm | d ₂ max. mm | d ₃ min. mm | b ₂ max. mm | C | | | | | | | | | | R | |
| 10 B – 2 HB | B | 0.625 | 15.875 | 9.65 | 10.16 | 5.94 | 4 | 13.9 | 14.7 | 17.8 | 37.3 | 39.0 | 2.08 | 33 500 | 1.6 | | | | | |
| 12 B – 2 HB | B | 0.75 | 19.05 | 11.68 | 12.07 | 6.5 | 4 | 16.3 | 15.9 | 20.6 | 43.0 | 45.0 | 2.12 | 42 500 | 2.2 | | | | | |

1) Bush-Ø

*) Details about the effective higher Rexnord ultimate strengths and fatigue strength values are available upon request.

RexPlus roller chains in rust and acid-resistant steel



**Extremely resistant to rust,
acid, fatigue and wear.**

**RexPlus roller chains are manufactured from patented material.
RexPlus chains also as duplex and driplex chain available.
See also in the Rexnord Expertise Leaf let.**

Roller chains, single-strand, made from rust and acid-resistant steel

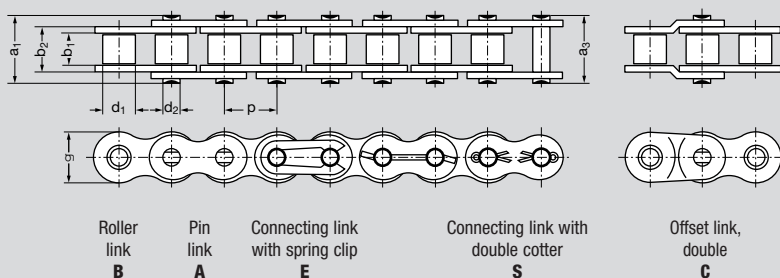

| Chain No. | Pitch p | | Roller width b ₁ min. mm | Roller Ø d ₁ max. mm | Pin Ø d ₂ max. mm | Inner width b ₂ max. mm | Link plate height g mm | Transverse e mm | Pin length a ₁ max. mm | Overall width a ₃ max. mm | Bearing area A cm ² | Min. ultimate strength*) F _B N | Weight ≈ q kg/m | Loose parts | |
|--------------------|---------|--------|--|------------------------------------|---------------------------------|---------------------------------------|---------------------------|--------------------|--------------------------------------|---|-----------------------------------|--|--------------------|-------------|---|
| | inch | mm | | | | | | | | | | | | C | E |
| 08 B - 1 SS | 0.50 | 12.70 | 7.75 | 8.51 | 4.45 | 11.30 | 11.6 | — | 16.7 | 18.2 | 0.50 | 11 000 | 0.71 | x | x |
| 10 B - 1 SS | 0.625 | 15.875 | 9.65 | 10.16 | 5.08 | 13.28 | 14.6 | — | 18.9 | 20.4 | 0.67 | 14 000 | 0.93 | x | x |
| 12 B - 1 SS | 0.75 | 19.05 | 11.68 | 12.07 | 5.72 | 15.62 | 15.9 | — | 22.3 | 23.5 | 0.89 | 17 000 | 1.25 | x | x |
| 16 B - 1 SS | 1.00 | 25.40 | 17.02 | 15.88 | 8.28 | 25.40 | 20.5 | — | 35.4 | 37.6 | 2.10 | 40 000 | 2.70 | x | x |
| 50 - 1 SS | 0.625 | 15.875 | 9.40 | 10.16 | 5.08 | 13.80 | 14.6 | — | 20.4 | 21.8 | 0.70 | 16 500 | 1.00 | x | x |

Roller chains, double-strand, made from rust and acid-resistant steel

| Chain No. | Pitch p | | Roller width b ₁ min. mm | Roller Ø d ₁ max. mm | Pin Ø d ₂ max. mm | Inner width b ₂ max. mm | Link plate height g mm | Transverse e mm | Pin length a ₁ max. mm | Overall width a ₃ max. mm | Bearing area A cm ² | Min. ultimate strength *) F _B N | Weight ≈ q kg/m | Loose parts | |
|--------------------|---------|--------|--|------------------------------------|---------------------------------|---------------------------------------|---------------------------|--------------------|--------------------------------------|---|-----------------------------------|---|--------------------|-------------|---|
| | inch | mm | | | | | | | | | | | | C | E |
| 08 B - 2 SS | 0,50 | 12,70 | 7,75 | 8,51 | 4,45 | 11,30 | 11,6 | 13,92 | 31,0 | 32,2 | 1,00 | 19 500 | 1,35 | x | x |
| 10 B - 2 SS | 0,625 | 15,875 | 9,65 | 10,16 | 5,08 | 13,28 | 14,6 | 16,59 | 35,5 | 37,2 | 1,34 | 25 000 | 1,83 | x | x |
| 12 B - 2 SS | 0,75 | 19,05 | 11,68 | 12,07 | 5,72 | 15,62 | 15,9 | 19,46 | 41,7 | 43,0 | 1,78 | 30 000 | 2,37 | x | x |
| 16 B - 2 SS | 1,00 | 25,40 | 17,02 | 15,88 | 8,28 | 25,45 | 20,5 | 31,88 | 67,1 | 69,5 | 4,20 | 71 000 | 5,30 | | x |
| 50 - 2 SS | 0,625 | 15,875 | 9,40 | 10,16 | 5,08 | 13,80 | 14,6 | 18,11 | 38,5 | 33,9 | 1,40 | 33 000 | 2,04 | | x |

*) Details about the effective higher Rexnord ultimate strengths and fatigue strength values are available upon request.

Side bow roller chains



For constructions with curves.

**Links A and B are available for all chains.
Attachments upon request.**

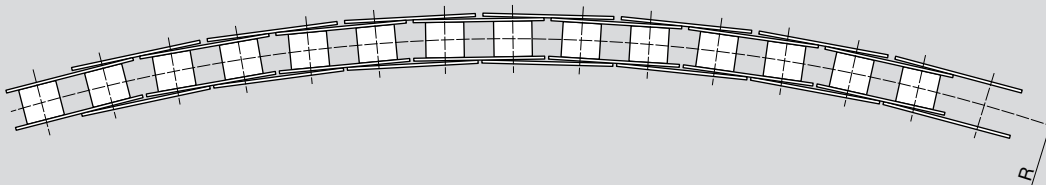
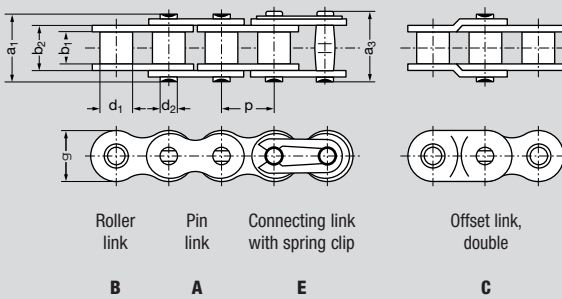

Side bow roller chains, main dimensions acc. to European standard (DIN 8187)

| Chain No. | Pitch p | | Roller width b ₁ min. mm | Roller Ø d ₁ max. mm | Pin Ø d ₂ max. mm | Inner width b ₂ max. mm | Link plate height g mm | Pin length a ₁ max. mm | Overall width a ₃ max. mm | Radius R min. | Min. ultimate strength*) F _B N | Weight ≈ q kg/m | Loose parts | |
|-------------|---------|--------|--|------------------------------------|---------------------------------|---------------------------------------|---------------------------|--------------------------------------|---|------------------|--|--------------------|-------------|---|
| | inch | mm | | | | | | | | | | | C | E |
| 08 B – 1 SB | 0,50 | 12,70 | 7,75 | 8,51 | 4,45 | 11,30 | 11,8 | 17,1 | 18,3 | 315 | 11 200 | 0,71 | x | x |
| 10 B – 1 SB | 0,625 | 15,875 | 9,65 | 10,16 | 5,08 | 13,28 | 14,7 | 19,4 | 20,6 | 400 | 15 000 | 0,92 | x | x |
| 12 B – 1 SB | 0,75 | 19,05 | 11,68 | 12,07 | 5,72 | 15,61 | 15,9 | 22,5 | 23,7 | 500 | 20 000 | 1,20 | x | x |

Side bow roller chains, main dimensions acc. to American standard (DIN 8188)

| Chain No. | Pitch p | | Roller width b ₁ min. mm | Roller Ø d ₁ max. mm | Pin Ø d ₂ max. mm | Inner width b ₂ max. mm | Link plate height g mm | Pin length a ₁ max. mm | Overall width länge a ₃ max. mm | Radius R min. | Min. ultimate strength*) F _B N | Weight ≈ q kg/m | Loose parts | |
|-----------|---------|--------|--|------------------------------------|---------------------------------|---------------------------------------|---------------------------|--------------------------------------|--|------------------|--|--------------------|-------------|---|
| | inch | mm | | | | | | | | | | | C | E |
| 40 – 1 SB | 0,50 | 12,70 | 7,85 | 7,92 | 3,96 | 11,18 | 11,6 | 16,6 | 17,8 | 315 | 9 000 | 0,64 | x | x |
| 50 – 1 SB | 0,625 | 15,875 | 9,40 | 10,16 | 5,08 | 13,84 | 14,6 | 20,8 | 22,1 | 400 | 15 000 | 1,10 | x | x |
| 60 – 1 SB | 0,75 | 19,05 | 12,57 | 11,91 | 5,94 | 17,75 | 17,7 | 25,7 | 27,1 | 500 | 22 400 | 1,50 | x | x |

*) Details about the effective higher Rexnord ultimate strengths and fatigue strength values are available upon request.

Double-pitch roller chains



High efficiency - Low weight.

Links A and B are available for all chains.

1) also available with Delrin rollers

Double-pitch roller chains, ISO 1275 / DIN 8181

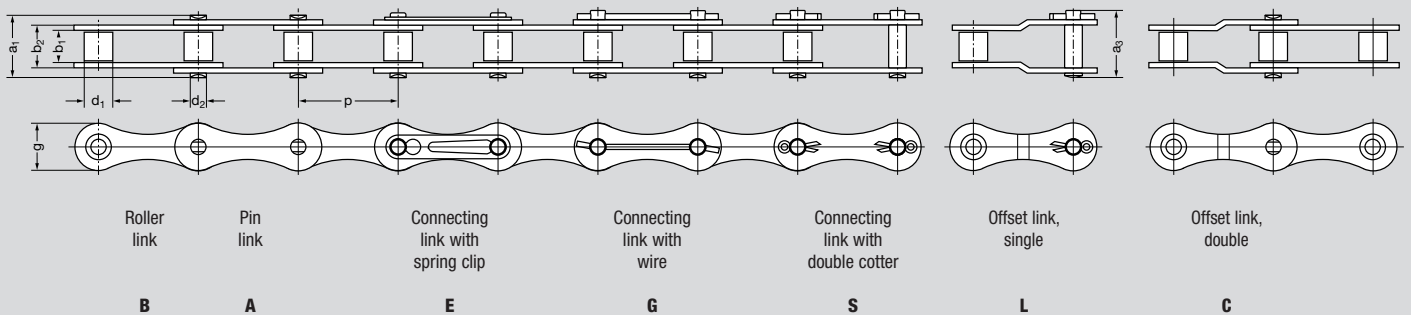

European standard

| Chain No. | Pitch p | | Roller width b ₁ min. mm | Roller Ø d ₁ max. mm | Pin Ø d ₂ max. mm | Inner width b ₂ max. mm | Link plate height g mm | Pin length a ₁ max. mm | Overall width a ₃ max. mm | Bearing area A cm ² | Min. ultimate strength required*) acc. to DIN/ISO F _B N | Weight ≈ q kg/m | Loose parts | | | |
|--------------|---------|-------|--|------------------------------------|---------------------------------|---------------------------------------|---------------------------|--------------------------------------|---|-----------------------------------|--|--------------------|-------------|---|---|---|
| | inch | mm | | | | | | | | | | | S | C | E | L |
| 208 B | 1,00 | 25,4 | 7,75 | 8,51 | 4,45 | 11,30 | 11,5 | 16,7 | 18,9 | 0,50 | 18 000 | 0,45 | x | x | x | x |
| 210 B | 1,25 | 31,75 | 9,65 | 10,16 | 5,08 | 13,28 | 14,5 | 18,9 | 21,8 | 0,67 | 22 400 | 0,59 | x | x | x | x |
| 212 B | 1,50 | 38,1 | 11,68 | 12,07 | 5,72 | 15,62 | 15,9 | 22,3 | 24,7 | 0,89 | 29 000 | 0,74 | x | x | x | x |
| 216 B | 2,00 | 50,8 | 17,02 | 15,88 | 8,28 | 25,40 | 21,4 | 35,4 | 38,4 | 2,10 | 60 000 | 1,71 | x | x | | x |

American standard

| Chain No. | Pitch p | | Roller width b ₁ min. mm | Roller Ø d ₁ max. mm | Pin Ø d ₂ max. mm | Inner width b ₂ max. mm | Link plate height g mm | Pin length a ₁ max. mm | Overall width a ₃ max. mm | Bearing area A cm ² | Min. ultimate strength required*) acc. to DIN/ISO F _B N | Weight ≈ q kg/m | Loose parts | | | |
|--------------|---------|-------|--|------------------------------------|---------------------------------|---------------------------------------|---------------------------|--------------------------------------|---|-----------------------------------|--|--------------------|-------------|---|---|---|
| | inch | mm | | | | | | | | | | | S | C | E | L |
| 208 A | 1,00 | 25,4 | 7,85 | 7,95 | 3,96 | 11,15 | 11,5 | 16,3 | 19,8 | 0,44 | 14 100 | 0,42 | x | x | x | x |
| 210 A | 1,25 | 31,75 | 9,40 | 10,16 | 5,08 | 13,8 | 14,5 | 20,3 | 24,5 | 0,70 | 22 200 | 0,67 | x | x | x | x |
| 212 A | 1,50 | 38,1 | 12,57 | 11,91 | 5,94 | 17,7 | 16,8 | 25,7 | 29,6 | 1,05 | 31 800 | 1,02 | x | x | x | x |
| 216 A | 2,00 | 50,8 | 15,75 | 15,88 | 7,92 | 22,5 | 21,4 | 33,0 | 37,4 | 1,78 | 56 700 | 1,55 | x | x | | x |

*) Details about the effective higher Rexnord ultimate strengths and fatigue strength values are available upon request.

Double-pitch roller chains with straight link plates and carrier rollers, American standard, ISO 1275

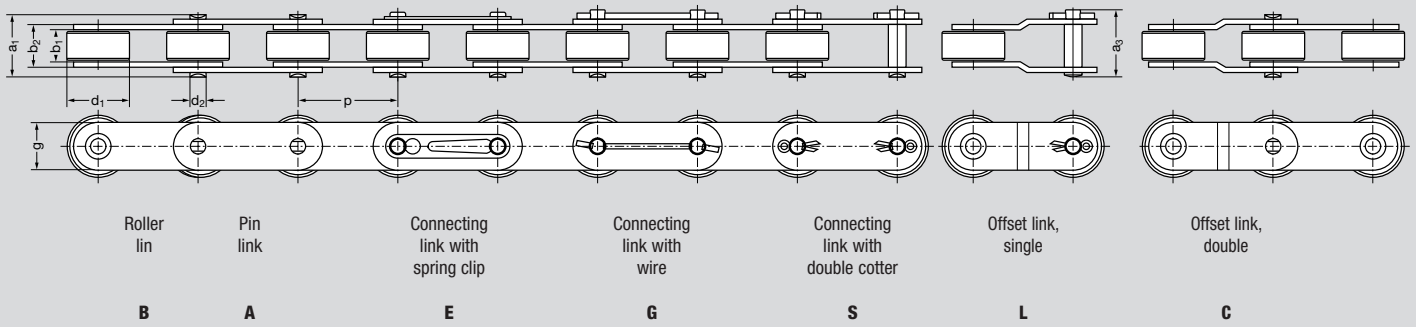

| Chain No. | Pitch p | | Roller width b ₁ min. mm | Roller Ø d ₁ max. mm | Pin Ø d ₂ max. mm | Inner width b ₂ max. mm | Link plate height g mm | Pin length a ₁ max. mm | Overall width a ₃ max. mm | Bearing area A cm ² | Min. ultimate strength required*) acc. to DIN/ISO F _B N | Weight ≈ q kg/m | Loose parts | | | |
|------------------------------|---------|-------|--|------------------------------------|---------------------------------|---------------------------------------|---------------------------|--------------------------------------|---|-----------------------------------|--|--------------------|-------------|---|---|---|
| | inch | mm | | | | | | | | | | | S | C | E | L |
| | | | | | | | | | | | | | | G | | |
| C 2042 | 1,00 | 25,4 | 7,85 | 15,88 | 3,96 | 11,15 | 11,5 | 16,3 | 20,3 | 0,44 | 14 100 | 0,85 | x | | x | x |
| C 2052 | 1,25 | 31,75 | 9,40 | 19,05 | 5,08 | 13,8 | 14,5 | 20,3 | 24,5 | 0,70 | 22 200 | 1,27 | x | | x | x |
| C 2062 H¹⁾ | 1,50 | 38,1 | 12,57 | 22,23 | 5,94 | 19,4 | 16,8 | 28,8 | 32,0 | 1,15 | 31 800 | 2,10 | x | x | x | x |
| C 2082 H¹⁾ | 2,00 | 50,8 | 15,75 | 28,58 | 7,93 | 24,2 | 22,8 | 35,9 | 41,0 | 1,94 | 56 700 | 3,44 | x | x | | |

Double-pitch roller chains with straight link plates, American standard, ISO 1275

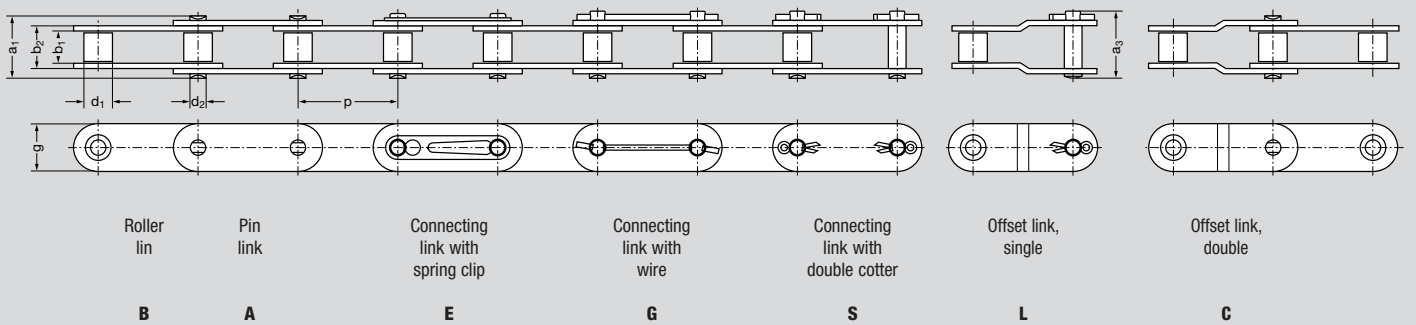

| Chain No. | Pitch p | | Roller width b ₁ min. mm | Roller Ø d ₁ max. mm | Pin Ø d ₂ max. mm | Inner width b ₂ max. mm | Link plate height g mm | Pin length a ₁ max. mm | Overall width a ₃ max. mm | Bearing area A cm ² | Min. ultimate strength required*) acc. to DIN/ISO F _B N | Weight ≈ q kg/m | Loose parts | | | |
|-----------------|---------|-------|--|------------------------------------|---------------------------------|---------------------------------------|---------------------------|--------------------------------------|---|-----------------------------------|--|--------------------|-------------|---|---|---|
| | inch | mm | | | | | | | | | | | S | C | E | L |
| | | | | | | | | | | | | | | G | | |
| C 2040 | 1,00 | 25,4 | 7,85 | 7,95 | 3,96 | 11,15 | 11,5 | 16,3 | 20,3 | 0,44 | 14 100 | 0,48 | x | x | x | x |
| C 2050 | 1,25 | 31,75 | 9,40 | 10,16 | 5,08 | 13,8 | 14,5 | 20,3 | 24,5 | 0,70 | 22 200 | 0,80 | x | x | x | x |
| C 2060 H | 1,50 | 38,1 | 12,57 | 11,91 | 5,94 | 19,4 | 16,8 | 28,8 | 32,9 | 1,15 | 31 800 | 1,49 | x | x | x | x |
| C 2080 H | 2,00 | 50,8 | 15,75 | 15,88 | 7,92 | 24,2 | 22,8 | 35,3 | 41,0 | 1,92 | 56 700 | 2,36 | x | x | | |

*) Details about the effective higher Rexnord ultimate strengths and fatigue strength values are available upon request.

Agricultural roller chains



Reliable and fatigue resistant - even in rough applications.

Rexnord offers a far-reaching program of standard and special carriers and attachments for double-pitch roller chains in the agricultural series (S series).

Please see the Rexnord agricultural chain catalogue.

Agricultural roller chains, ISO 487 / DIN 8189

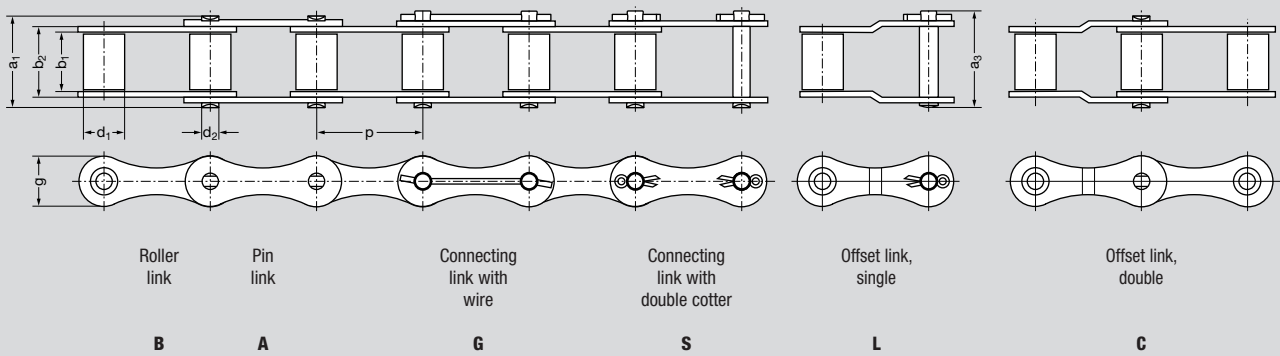

| Chain description | | Pitch | | Roller width | Roller \varnothing | Pin \varnothing | Inner width | Link plate height | Pin length | Overall-width | Bearing area | Min. ultimate strength* | Weight | Loose parts | | | |
|-------------------|---------|-------|-------|------------------------|------------------------|------------------------|------------------------|-------------------|------------------------|------------------------|-------------------|-------------------------|----------|-------------|---|---|---|
| Chain No. | ISO No. | p | | b ₁ min. mm | d ₁ max. mm | d ₂ max. mm | b ₂ max. mm | g mm | a ₁ max. mm | a ₃ max. mm | A cm ² | F _B N | ≈ q kg/m | G | S | C | L |
| RL 640 | S 32 | 1.15 | 29.21 | 15.88 | 11.43 | 4.47 | 20.19 | 13.5 | 26.7 | 29.6 | 0.90 | 20 000 | 0.76 | x | | x | |
| RL 670 | S 42 | 1.375 | 34.93 | 19.05 | 14.27 | 7.0 | 25.40 | 19.6 | 34.25 | 36.7 | 1.78 | 27 000 | 1.49 | x | x | | x |
| SK 742 | S 45 | 1.63 | 41.40 | 22.23 | 15.24 | 5.74 | 28.58 | 17.2 | 38.1 | 40.6 | 1.63 | 25 000 | 1.46 | x | x | x | x |
| RL 741 | S 52 | 1.50 | 38.10 | 22.23 | 15.24 | 5.74 | 28.58 | 17.3 | 38.1 | 40.6 | 1.63 | 25 000 | 1.56 | x | x | x | x |
| SK 744 | S 55 | 1.63 | 41.40 | 22.23 | 17.78 | 5.74 | 28.58 | 17.3 | 38.1 | 40.6 | 1.63 | 25 000 | 1.65 | x | x | x | x |
| RL 747 | S 62 | 1.65 | 41.91 | 25.40 | 19.05 | 5.72 | 30.60 | 17.0 | 40.5 | 42.6 | 1.82 | 28 000 | 1.95 | x | x | | x |
| RL 942 | S 77 | 2.30 | 58.34 | 22.23 | 18.26 | 8.92 | 30.90 | 24.6 | 43.8 | 49.2 | 2.77 | 45 000 | 2.35 | x | x | | x |
| RL 1042 | S 88 | 2.60 | 66.27 | 28.58 | 22.86 | 8.92 | 37.52 | 24.2 | 50.2 | 55.5 | 3.34 | 45 000 | 2.78 | x | x | | x |

*) Details about the effective higher Rexnord ultimate strengths and fatigue strength values are available upon request.

Agricultural roller chains, Industry standard

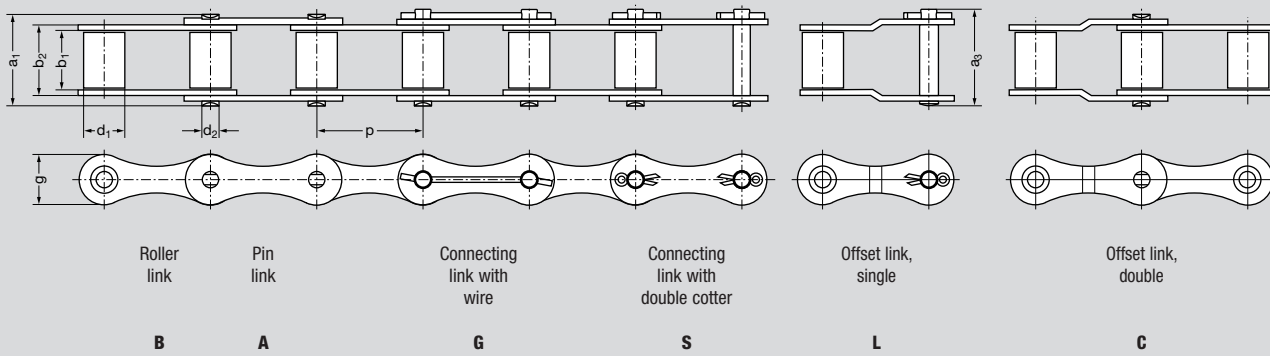

| Chain description | | Pitch | | Roller width | Roller \varnothing | Pin \varnothing | Inner width | Link plate height | Pin length | Overall-width | Bearing area | Min. ultimate strength* | Weight | Loose parts | | | |
|-------------------|-------------|-------|------|--------------|----------------------|-------------------|-------------|-------------------|------------|---------------|--------------|-------------------------|--------|------------------------|------------------------|------------------------|------------------------|
| | | p | | | | | | | | | | | | b ₁ min. mm | d ₁ max. mm | d ₂ max. mm | b ₂ max. mm |
| old | new | inch | mm | | | | | | | | | | | | | | |
| SK 627 | 30-1 BG GL | 1.18 | 30.0 | 19.05 | 15.88 | 8.27 | 25.45 | 20.5 | 35.6 | 39.0 | 2.1 | 45 000 | 2.45 | x | x | | |
| RL 726 | S 52 BK | 1.50 | 38.1 | 16.0 | 15.24 | 5.72 | 21.9 | 17.0 | 30.5 | 33.8 | 1.2 | 28 000 | 1.42 | x | x | x | x |
| RL 738 | 38.4 GL | 1.50 | 38.4 | 19.05 | 15.88 | 6.92 | 23.9 | 17.0 | 33.7 | 37.55 | 1.67 | 31 500 | 1.68 | x | x | x | x |
| SK 717 | 38.4 H GL | 1.50 | 38.4 | 19.05 | 15.88 | 8.27 | 25.45 | 20.1 | 35.6 | 39.75 | 2.1 | 45 000 | 2.10 | x | x | x | x |
| RL 753 | S 55 SK8 H | 1.63 | 41.4 | 20.5 | 15.88 | 7.97 | 27.0 | 20.0 | 37.2 | 41.6 | 2.15 | 42 500 | 1.75 | x | x | x | x |
| RL 764 | S 55 H | 1.63 | 41.4 | 22.23 | 17.9 | 8.26 | 29.23 | 20.5 | 39.3 | 42.8 | 2.36 | 47 500 | 2.04 | x | x | | x |
| RL 766 | S 55 SK2 GL | 1.63 | 41.4 | 22.23 | 15.88 | 8.26 | 28.03 | 20.5 | 39.3 | 44.6 | 2.56 | 60 000 | 2.20 | x | x | | x |
| RL 774 | S 55 SK6 GL | 1.63 | 41.4 | 19.81 | 16.87 | 7.19 | 25.45 | 19.0 | 35.6 | 39.7 | 1.86 | 47 500 | 1.95 | x | x | | x |
| SK 838 | 216 B SK1 | 2.00 | 50.8 | 19.0 | 19.05 | 9.53 | 27.4 | 26.0 | 40.0 | 44.0 | 2.62 | 85 000 | 2.62 | | x | | |

Agricultural roller chains with thermoplastic bearings

| Chain description | | Pitch | | Roller width | Roller \varnothing | Pin \varnothing | Inner width | Link plate height | Pin length | Overall-width | Bearing area | Min. ultimate strength* | Weight | Loose parts | | | |
|-------------------|------------|-------|------|--------------|----------------------|-------------------|-------------|-------------------|------------|---------------|--------------|-------------------------|--------|------------------------|------------------------|------------------------|------------------------|
| | | p | | | | | | | | | | | | b ₁ min. mm | d ₁ max. mm | d ₂ max. mm | b ₂ max. mm |
| old | new | inch | mm | | | | | | | | | | | | | | |
| RLK 738 | 38.4 GL KL | 1,50 | 38,4 | 19,05 | 15,88 | 6,93 | 24,2 | 17,0 | 32,8 | 30,5 | 1,66 | 23 600 | 1,63 | x | x | x | x |

*) Details about the effective higher Rexnord ultimate strengths and fatigue strength values are available upon request.

Leaf chains



Safety lifting chains.

Leaf Chains are often a safety-critical component part. For this reason Rexnord Leaf Chains are supplied marked with a batch number. This allows traceability to process and inspection records right back to the raw material and its supplier.

Leaf chains, odd lacings

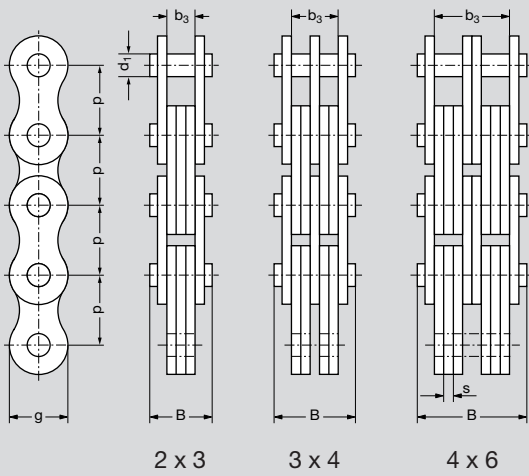

Leaf chains, even lacings

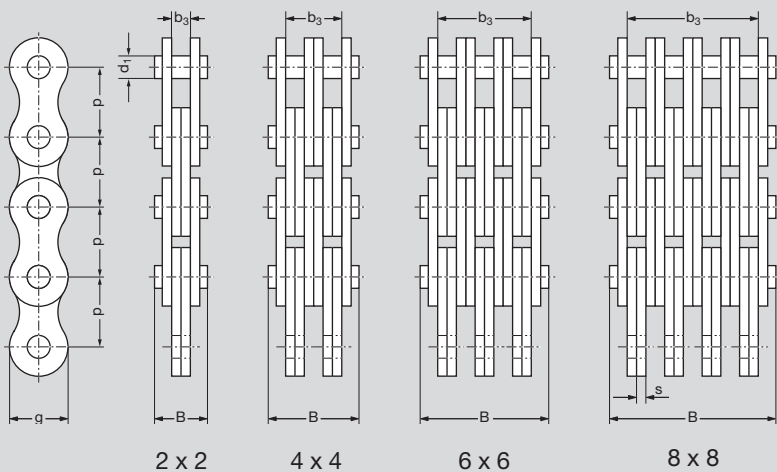

Leaf chains acc. to ISO 4347 / DIN 8152, American standard, Heavy series

| Chain No. | Chain description ISO DIN | Pitch p | | Plate combinations | Pin ∅ d ₁ max. mm | Link plate height g mm | Link plate thick s mm | Length over 100 x Pitch ■ mm | Total width B max. mm | Bearing area A cm ² | Link plate width b ₃ min. mm | Min. ultimate strength required*) acc. to DIN ISO F _B N | Weight ≈ q kg/m |
|-----------|---------------------------------|------------|--------|--------------------|---------------------------------------|------------------------------|-----------------------------|---------------------------------------|-----------------------------|--------------------------------------|---|---|-----------------------|
| | | inch | mm | | | | | | | | | | |
| BL 422 | LH 0822 | 0.50 | 12.7 | 2 x 2 | 5.08 | 11.7 | 2.0 | 1277 | 10.9 | 0.20 | 4.2 | 22 200 | 0.60 |
| BL 423 | LH 0823 | | | 2 x 3 | | | | | 13.0 | 0.30 | 6.3 | 22 200 | 0.65 |
| BL 434 | LH 0834 | | | 3 x 4 | | | | | 17.1 | 0.41 | 10.5 | 33 300 | 0.90 |
| BL 444 | LH 0844 | | | 4 x 4 | | | | | 19.25 | 0.41 | 12.6 | 44 400 | 1.02 |
| BL 446 | LH 0846 | | | 4 x 6 | | | | | 23.45 | 0.61 | 16.8 | 44 400 | 1.26 |
| BL 466 | LH 0866 | | | 6 x 6 | | | | | 27.6 | 0.61 | 21.0 | 66 600 | 1.51 |
| BL 523 | LH 1023 | 0.625 | 15.875 | 2 x 3 | 5.94 | 14.6 | 2.4 | 1596 | 15.0 | 0.43 | 7.4 | 33 400 | 1.1 |
| BL 534 | LH 1034 | | | 3 x 4 | | | | | 20.0 | 0.57 | 12.3 | 50 100 | 1.5 |
| BL 544 | LH 1044 | | | 4 x 4 | | | | | 22.5 | 0.57 | 14.7 | 66 800 | 1.8 |
| BL 546 | LH 1046 | | | 4 x 6 | | | | | 27.3 | 0.86 | 19.6 | 66 800 | 2.2 |
| BL 566 | LH 1066 | | | 6 x 6 | | | | | 32.3 | 0.86 | 24.5 | 100 200 | 2.6 |
| BL 588 | LH 1088 | | | 8 x 8 | | | | | 42.2 | 1.14 | 34.3 | 133 600 | 3.4 |
| BL 622 | LH 1222 | 0.75 | 19.05 | 2 x 2 | 7.92 | 17.8 | 3.1 | 1908 | 16.6 | 0.51 | 6.4 | 48 900 | 1.5 |
| BL 623 | LH 1223 | | | 2 x 3 | | | | | 19.9 | 0.74 | 9.6 | 48 900 | 1.8 |
| BL 634 | LH 1234 | | | 3 x 4 | | | | | 26.5 | 0.98 | 16.0 | 73 400 | 2.5 |
| BL 644 | LH 1244 | | | 4 x 4 | | | | | 29.7 | 0.98 | 19.3 | 97 800 | 2.9 |
| BL 646 | LH 1246 | | | 4 x 6 | | | | | 36.3 | 1.47 | 25.8 | 97 800 | 3.6 |
| BL 666 | LH 1266 | | | 6 x 6 | | | | | 42.7 | 1.47 | 32.2 | 146 900 | 4.3 |
| BL 822 | LH 1622 | 1.00 | 25.4 | 2 x 2 | 9.53 | 23.6 | 4.0 | 2540 | 20.6 | 0.74 | 8.2 | 84 500 | 2.4 |
| BL 823 | LH 1623 | | | 2 x 3 | | | | | 24.8 | 1.14 | 12.3 | 84 500 | 3.0 |
| BL 834 | LH 1634 | | | 3 x 4 | | | | | 33.1 | 1.52 | 20.5 | 126 800 | 4.8 |
| BL 844 | LH 1644 | | | 4 x 4 | | | | | 37.3 | 1.52 | 24.7 | 169 000 | 6.0 |
| BL 846 | LH 1646 | | | 4 x 6 | | | | | 45.7 | 2.29 | 33.0 | 169 000 | 7.2 |
| BL 866 | LH 1666 | | | 6 x 6 | | | | | 54.0 | 2.29 | 41.3 | 253 600 | 9.6 |
| BL 888 | LH 1688 | 8 x 8 | 70.7 | 2.97 | 57.9 | 338 000 | 9.6 | | | | | | |
| BL 1023 | LH 2023 | 1.25 | 31.75 | 2 x 3 | 11.1 | 29.2 | 4.7 | 3179 | 28.9 | 1.56 | 14.4 | 115 600 | 4.4 |
| BL 1034 | LH 2034 | | | 3 x 4 | | | | | 38.7 | 2.09 | 24.0 | 173 400 | 6.2 |
| BL 1044 | LH 2044 | | | 4 x 4 | | | | | 43.7 | 2.09 | 28.8 | 231 200 | 7.0 |
| BL 1046 | LH 2046 | | | 4 x 6 | | | | | 53.5 | 3.12 | 38.4 | 231 200 | 8.7 |
| BL 1066 | LH 2066 | | | 6 x 6 | | | | | 63.4 | 3.12 | 48.0 | 346 800 | 10.5 |
| BL 1088 | LH 2088 | | | 8 x 8 | | | | | 83.0 | 4.17 | 67.2 | 462 400 | 13.9 |
| BL 1223 | LH 2423 | 1.50 | 38.1 | 2 x 3 | 12.7 | 34.4 | 5.5 | 3812 | 33.6 | 2.10 | 16.8 | 151 200 | 6.0 |
| BL 1234 | LH 2434 | | | 3 x 4 | | | | | 45.5 | 2.79 | 28.0 | 226 800 | 8.3 |
| BL 1244 | LH 2444 | | | 4 x 4 | | | | | 51.2 | 2.79 | 33.6 | 302 400 | 9.5 |
| BL 1246 | LH 2446 | | | 4 x 6 | | | | | 62.7 | 4.2 | 44.8 | 302 400 | 11.8 |
| BL 1266 | LH 2466 | | | 6 x 6 | | | | | 74.5 | 4.2 | 56.0 | 453 600 | 14.1 |
| BL 1288 | LH 2488 | | | 8 x 8 | | | | | 97.8 | 5.4 | 78.4 | 604 800 | 18.8 |
| BL 1423 | LH 2823 | 1.75 | 44.45 | 2 x 3 | 14.27 | 40.8 | 6.3 | 4445 | 38.2 | 2.7 | 19.2 | 191 300 | 8.3 |
| BL 1434 | LH 2834 | | | 3 x 4 | | | | | 51.7 | 3.6 | 32.0 | 287 000 | 11.6 |
| BL 1444 | LH 2844 | | | 4 x 4 | | | | | 58.2 | 3.6 | 38.4 | 382 600 | 13.2 |
| BL 1446 | LH 2846 | | | 4 x 6 | | | | | 71.5 | 5.4 | 51.2 | 382 600 | 16.4 |
| BL 1466 | LH 2866 | | | 6 x 6 | | | | | 85.0 | 5.4 | 64.0 | 574 000 | 19.7 |
| BL 1488 | LH 2888 | | | 8 x 8 | | | | | 111.7 | 7.2 | 89.6 | 765 200 | 25.9 |
| BL 1623 | LH 3223 | 2.00 | 50.8 | 2 x 3 | 17.46 | 47.9 | 7.0 | 5080 | 42.1 | 3.67 | 21.3 | 289 100 | 11.0 |
| BL 1634 | LH 3234 | | | 3 x 4 | | | | | 57.0 | 4.89 | 35.5 | 433 700 | 15.4 |
| BL 1644 | LH 3244 | | | 4 x 4 | | | | | 63.8 | 5.0 | 42.6 | 578 200 | 17.5 |
| BL 1646 | LH 3246 | | | 4 x 6 | | | | | 78.9 | 7.33 | 56.8 | 578 200 | 21.8 |
| BL 1666 | LH 3266 | | | 6 x 6 | | | | | 95.0 | 7.33 | 71.0 | 867 400 | 26.2 |
| BL 1688 | LH 3288 | | | 8 x 8 | | | | | 125.6 | 9.78 | 99.4 | 1 156 400 | 34.9 |

BL leaf chains can be directly fastened by using connecting pins. They do not need additional end plates.

Wherever possible, it is best to select BL- leaf chains.

Further plate combinations upon request.

Please note the following the specs.:

Length over 100 x Pitch

■ chain length: Tolerance ± 0.25 % of uncoiled chain under measured load. Measured force = $\frac{F_B}{100}$

F = pin and plate dimensions correspond to roller chain series acc. to DIN 8187.

AL = pin and plate dimensions correspond to ANSI standard.

BL = pin and plate dimensions correspond to ANSI standard, however these leaf chains possess the plate thickness and pin ∅ of the next largest corresponding chain size, to achieve a larger bearing area and tensile strength, and consequently longer working life for the BL leaf chains.

*) Details about the effective higher Rexnord ultimate strengths and fatigue strength values are available upon request.

Leaf chains



F Series:
Machine tool quality.

Use machine tool chains from the "F" series in special machine tool quality!

The effective pitch dimensions for leaf chains from the series F and AL vary somewhat from the theoretical values. Please note the following specs.: "Length over 100 x Pitch".

■ Chain length: Tolerance $\pm 0,25\%$ of uncoiled chain under measured load. Measured force = $\frac{F_B}{100}$

Leaf chains, Lacings

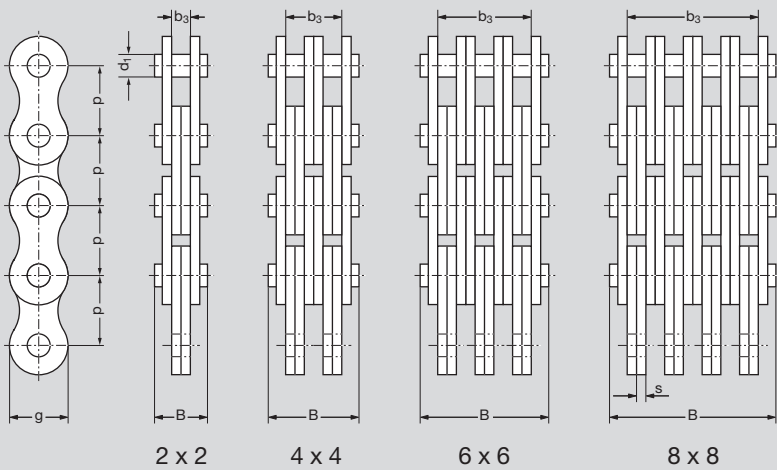

Leaf chains, Industry standard

| Chain No. | Chain description | Pitch p | | Plate combinations | Pin \varnothing | Link plate height | Link plate thick | Length over 100 x Pitch | Total width | Bearing area | Min. ultimate strength*) | Weight |
|--------------|-------------------|---------|--------|--------------------|-------------------|-------------------|------------------|-------------------------|-------------|--------------|--------------------------|--------|
| | | inch | mm | | | | | | | | | |
| F 6 H - 5 | — | 0.625 | 15.875 | 2 x 3 | 4.75 | 14.6 | 2.5 | 1592 | 14.9 | 0.24 | 30 300 | 1.0 |
| F 19 V - 44 | — | 0.75 | 19.05 | 4 x 4 | 6.5 | 15.2 | 2.35 | 1905 | 22.8 | 0.61 | 71 000 | 1.7 |
| F 19 V - 66 | — | — | — | 6 x 6 | — | — | — | — | 32.7 | 0.91 | 106 000 | 2.5 |
| 834 (SK 507) | — | 1.00 | 25.4 | 3 x 4 | 10.85 | 23.4 | IL /AL | 2544 | 28.4 | 1.37 | 125 000 | 3.6 |
| 432 (SK 508) | — | — | — | 6 x 6 | — | — | 3.05/4.0 | — | 44.4 | 2.06 | 250 000 | 5.9 |

*) Details about the effective higher Rexnord ultimate strengths and fatigue strength values are available upon request.

Leaf chains acc. to ISO 4347 / DIN 8152, European standard, Light series

| Chain No. | Chain description ISO DIN | Pitch p | | Plate combinations | Pin Ø d ₁ max. mm | Link plate height g mm | Link plate thick s mm | Length over 100 x Pitch ■ mm | Total width B max. mm | Bearing area A cm ² | Link plate width b ₃ min. mm | Min. ultimate strength required*) acc. to DIN/ISO F _B N | Weight ≈ q kg/m |
|-----------|------------------------------|---------|--------|--------------------|---------------------------------|---------------------------|--------------------------|---------------------------------|--------------------------|-----------------------------------|--|--|--------------------|
| | | inch | mm | | | | | | | | | | |
| | | | | | | | | | | | | | |
| F 12 – 44 | LL 0844 | 0,50 | 12,7 | 4 x 4 | 4,45 | 10,4 | 1,5 | 1270 | 15,0 | 0,27 | 9,1 | 36 000 | 0,83 |
| F 12 – 66 | LL 0866 | | | 6 x 6 | | | | | 21,3 | 0,40 | 15,2 | 54 000 | 1,25 |
| F 15 – 44 | LL 1044 | 0,625 | 15,875 | 4 x 4 | 5,08 | 12,8 | 1,5 | 1588 | 15,2 | 0,30 | 9,6 | 44 800 | 0,92 |
| F 15 – 66 | LL 1066 | | | 6 x 6 | | | | | 21,7 | 0,46 | 16,0 | 67 200 | 1,4 |
| F 19 – 44 | LL 1244 | 0,75 | 19,05 | 4 x 4 | 5,72 | 15,9 | 1,8 | 1890 | 18,0 | 0,41 | 11,4 | 59 000 | 1,4 |
| F 19 – 66 | LL 1266 | | | 6 x 6 | | | | | 25,7 | 0,62 | 19,0 | 88 500 | 2,1 |
| F 25 – 44 | LL 1644 | 1,00 | 25,4 | 4 x 4 | 8,28 | 20,5 | 3,0 | 2540 | 28,4 | 0,99 | 18,6 | 120 000 | 2,9 |
| F 25 – 66 | LL 1666 | | | 6 x 6 | | | | | 40,7 | 1,49 | 31,0 | 180 000 | 4,3 |
| F 25 – 88 | LL 1688 | | | 8 x 8 | | | | | 53,0 | 1,98 | 43,4 | 240 000 | 5,8 |
| F 31 – 44 | LL 2044 | 1,25 | 31,75 | 4 x 4 | 10,19 | 25,7 | 3,5 | 3160 | 33,5 | 1,42 | 21,6 | 190 000 | 4,3 |
| F 31 – 66 | LL 2066 | | | 6 x 6 | | | | | 48,2 | 2,12 | 36,0 | 285 000 | 6,4 |
| F 31 – 88 | LL 2088 | | | 8 x 8 | | | | | 62,9 | 2,83 | 50,4 | 380 000 | 8,4 |
| F 38 – 44 | LL 2444 | 1,50 | 38,1 | 4 x 4 | 14,63 | 33,0 | 5,0 | 3785 | 46,9 | 2,91 | 31,2 | 320 000 | 8,2 |
| F 38 – 66 | LL 2466 | | | 6 x 6 | | | | | 68,3 | 4,37 | 52,4 | 480 000 | 12,2 |
| F 38 – 88 | LL 2488 | | | 8 x 8 | | | | | 89,7 | 5,82 | 73,5 | 640 000 | 16,2 |
| F 44 – 22 | LL 2822 | 1,75 | 44,45 | 2 x 2 | 15,9 | 36,0 | 6,0 | 4410 | 29,4 | 1,90 | 12,3 | 200 000 | 5,2 |
| F 44 – 44 | LL 2844 | | | 4 x 4 | | | | | 54,7 | 3,80 | 36,8 | 400 000 | 10,4 |
| F 44 – 66 | LL 2866 | | | 6 x 6 | | | | | 80,2 | 5,70 | 61,4 | 600 000 | 15,6 |
| F 44 – 88 | LL 2888 | | | 8 x 8 | | | | | 105,4 | 7,60 | 86,5 | 800 000 | 20,8 |
| F 50 – 22 | LL 3222 | 2,00 | 50,8 | 2 x 2 | 17,81 | 41,2 | 6,3 | 5048 | 32,5 | 2,24 | 12,9 | 250 000 | 6,5 |
| F 50 – 44 | LL 3244 | | | 4 x 4 | | | | | 59,1 | 4,47 | 39,1 | 500 000 | 12,8 |
| F 50 – 66 | LL 3266 | | | 6 x 6 | | | | | 85,4 | 6,71 | 65,6 | 750 000 | 19,1 |
| F 50 – 88 | LL 3288 | | | 8 x 8 | | | | | 112,0 | 8,94 | 92,0 | 1 000 000 | 25,3 |
| F 63 – 22 | LL 4022 | 2,50 | 63,5 | 2 x 2 | 22,89 | 48,0 | 8,0 | 6340 | 39,5 | 3,65 | 16,3 | 355 000 | 9,2 |
| F 63 – 44 | LL 4044 | | | 4 x 4 | | | | | 73,1 | 7,30 | 49,4 | 710 000 | 17,7 |
| F 63 – 66 | LL 4066 | | | 6 x 6 | | | | | 106,5 | 10,94 | 82,7 | 1 065 000 | 26,9 |
| F 63 – 88 | LL 4088 | | | 8 x 8 | | | | | 139,9 | 14,60 | 116,0 | 1 420 000 | 35,1 |
| F 76 – 22 | LL 4822 | 3,00 | 76,2 | 2 x 2 | 29,24 | 62,0 | 10,0 | 7620 | 49,7 | 5,83 | 20,3 | 560 000 | 15,4 |
| F 76 – 44 | LL 4844 | | | 4 x 4 | | | | | 91,2 | 11,66 | 60,6 | 1 120 000 | 30,2 |
| F 76 – 66 | LL 4866 | | | 6 x 6 | | | | | 131,0 | 17,50 | 101,0 | 1 680 000 | 45,0 |
| F 76 – 88 | LL 4888 | | | 8 x 8 | | | | | 172,8 | 23,30 | 144,0 | 2 240 000 | 59,8 |

Leaf chains, American standard, Light series

| Chain No. | Chain description ISO DIN | Pitch p | | Plate combinations | Pin Ø d ₁ max. mm | Link plate height g mm | Link plate thick s mm | Length over 100 x Pitch ■ mm | Total width B max. mm | Bearing area A cm ² | Link plate width b ₃ min. mm | Min. ultimate strength*) F _B N | Weight ≈ q kg/m |
|-----------|------------------------------|---------|--------|--------------------|---------------------------------|---------------------------|--------------------------|---------------------------------|--------------------------|-----------------------------------|--|--|--------------------|
| | | inch | mm | | | | | | | | | | |
| | | | | | | | | | | | | | |
| AL 422 | – | 0,50 | 12,7 | 2 x 2 | 3,96 | 10,2 | 1,5 | 1257 | 8,4 | 0,12 | 3,2 | 14 100 | 0,35 |
| AL 444 | – | | | 4 x 4 | | | | | 14,8 | 0,23 | 9,6 | 28 200 | 0,67 |
| AL 466 | – | | | 6 x 6 | | | | | 21,2 | 0,35 | 16,0 | 42 300 | 1,0 |
| AL 522 | – | 0,625 | 15,875 | 2 x 2 | 5,08 | 12,8 | 2,0 | 1572 | 10,8 | 0,2 | 4,2 | 22 000 | 0,6 |
| AL 544 | – | | | 4 x 4 | | | | | 19,2 | 0,4 | 12,6 | 44 000 | 1,2 |
| AL 566 | – | | | 6 x 6 | | | | | 21,7 | 0,6 | 21,0 | 66 000 | 1,8 |
| AL 622 | – | 0,75 | 19,05 | 2 x 2 | 5,94 | 14,8 | 2,4 | 1909 | 12,8 | 0,28 | 5,0 | 37 000 | 0,9 |
| AL 644 | – | | | 4 x 4 | | | | | 23,0 | 0,57 | 15,0 | 63 600 | 1,7 |
| AL 666 | – | | | 6 x 6 | | | | | 33,1 | 0,85 | 25,0 | 95 400 | 2,5 |
| AL 688 | – | | | 8 x 8 | | | | | 43,2 | 1,14 | 35,0 | 127 200 | 3,3 |
| AL 822 | – | 1,00 | 25,4 | 2 x 2 | 7,92 | 20,5 | 3,1 | 2540 | 16,6 | 0,51 | 6,3 | 56 700 | 1,5 |
| AL 844 | – | | | 4 x 4 | | | | | 29,7 | 1,01 | 19,0 | 113 400 | 3,0 |
| AL 866 | – | | | 6 x 6 | | | | | 42,7 | 1,52 | 31,8 | 170 100 | 4,5 |
| AL 1044 | – | 1,25 | 31,75 | 4 x 4 | 9,53 | 25,7 | 4,0 | 3175 | 37,3 | 1,52 | 24,6 | 177 000 | 4,9 |
| AL 1066 | – | | | 6 x 6 | | | | | 54,0 | 2,29 | 41,0 | 265 500 | 7,3 |
| AL 1244 | – | 1,50 | 38,1 | 4 x 4 | 11,1 | 29,4 | 4,7 | 3810 | 43,7 | 2,08 | 28,8 | 254 000 | 6,4 |
| AL 1266 | – | | | 6 x 6 | | | | | 63,4 | 3,12 | 48,0 | 381 000 | 9,5 |
| AL 1288 | – | | | 8 x 8 | | | | | 83,0 | 4,17 | 67,2 | 508 000 | 12,7 |
| AL 1444 | – | 1,75 | 44,45 | 4 x 4 | 12,7 | 36,0 | 5,5 | 4445 | 51,2 | 2,8 | 33,6 | 372 000 | 9,6 |
| AL 1466 | – | | | 6 x 6 | | | | | 74,5 | 4,2 | 56,0 | 558 000 | 14,4 |
| AL 1666 | – | 2,00 | 50,8 | 6 x 6 | 14,27 | 41,2 | 6,3 | 5080 | 85,0 | 5,39 | 64,0 | 642 000 | 18,9 |

*) Details about the effective higher Rexnord ultimate strengths and fatigue strength values are available upon request.

Fastening of leaf chains

Connecting pins for leaf chain fastening to fastening blocks

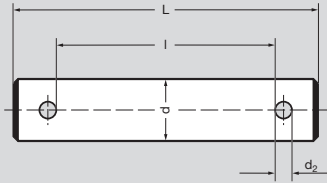

Each pin is fitted with 2 cotters and as from BL 1234 i.e. F 38 additionally with 2 washers.

| Chain No. | Connecting pin Order No. | Connecting pin dimensions (in mm) | | | |
|-----------------|--------------------------|-----------------------------------|--------|--------|----------------|
| | | l min. | L max. | d max. | d ₂ |
| F 12 - 44 | 709 - 204 - 44 | 16.0 | 22.2 | 4.45 | 1.6 |
| F 12 - 66 | 709 - 204 - 66 | 23.0 | 29.2 | | |
| F 15 - 44 | 709 - 205 - 44 | 15.0 | 21.1 | 5.08 | 1.6 |
| F 15 - 66 | 709 - 205 - 66 | 22.0 | 28.2 | | |
| F 19 - 44 | 709 - 405 - 44 | 17.6 | 25.5 | 5.72 | 2.0 |
| F 19 - 66 | 709 - 405 - 66 | 24.7 | 32.7 | | |
| F 25 - 44 | 709 - 208 - 44 | 28.0 | 38.7 | 8.28 | 3.2 |
| F 25 - 66 | 709 - 208 - 66 | 41.0 | 51.7 | | |
| F 25 - 88 | 709 - 208 - 88 | 54.0 | 64.7 | | |
| F 31 - 44 | 709 - 210 - 44 | 33.0 | 43.7 | 10.19 | 3.2 |
| F 31 - 66 | 709 - 210 - 66 | 47.0 | 57.7 | | |
| F 31 - 88 | 709 - 210 - 88 | 62.0 | 72.7 | | |
| F 38 - 44 | 709 - 214 - 44 | 48.2 | 60.6 | 14.63 | 4.0 |
| F 38 - 66 | 709 - 214 - 66 | 69.2 | 81.6 | | |
| F 38 - 88 | 709 - 214 - 88 | 90.2 | 102.6 | | |
| F 44 - 22 | 709 - 215 - 22 | 29.7 | 42.1 | 15.9 | 4.0 |
| F 44 - 44 | 709 - 215 - 44 | 55.0 | 67.5 | | |
| F 44 - 66 | 709 - 215 - 66 | 80.2 | 92.7 | | |
| F 44 - 88 | 709 - 215 - 88 | 106.0 | 118.5 | | |
| F 50 - 22 | 709 - 217 - 22 | 34.4 | 51.9 | | |
| F 50 - 44 | 709 - 217 - 44 | 59.9 | 77.5 | | |
| F 50 - 66 | 709 - 217 - 66 | 86.4 | 104.0 | | |
| F 50 - 88 | 709 - 217 - 88 | 113.9 | 131.5 | | |
| F 63 - 22 | 709 - 222 - 22 | 39.9 | 60.8 | 22.89 | 6.3 |
| F 63 - 44 | 709 - 222 - 44 | 73.3 | 94.3 | | |
| F 63 - 66 | 709 - 222 - 66 | 106.6 | 127.6 | | |
| F 63 - 88 | 709 - 222 - 88 | 140.1 | 161.1 | | |
| F 76 - 44 | 709 - 229 - 44 | 91.5 | 112.5 | 29.23 | 6.3 |
| F 76 - 66 | 709 - 229 - 66 | 133.5 | 154.5 | | |
| F 76 - 88 | 709 - 229 - 88 | 174.2 | 195.2 | | |
| F 19 V - 44 | 709 - 206 - 44 | 23.0 | 30.2 | 6.5 | 2.0 |
| F 19 V - 66 | 709 - 206 - 66 | 33.0 | 40.3 | | |
| BL 422/AL 522 | 709 - 305 - 22 | 10.8 | 17.0 | 5.08 | 1.6 |
| BL 423 | 709 - 305 - 23 | 12.7 | 18.9 | | |
| BL 434 | 709 - 305 - 34 | 17.0 | 23.2 | | |
| BL 444/AL 544 | 709 - 305 - 44 | 19.0 | 25.2 | | |
| BL 446 | 709 - 305 - 46 | 23.0 | 29.2 | | |
| BL 466/AL 566 | 709 - 305 - 66 | 27.0 | 33.3 | | |
| BL 488/AL 588 | 709 - 305 - 88 | 35.5 | 41.8 | | |
| BL 522/AL 622 | 709 - 355 - 22 | 12.8 | 19.4 | | |
| BL 523 | 709 - 355 - 23 | 15.0 | 21.6 | | |
| BL 534 | 709 - 355 - 34 | 20.0 | 26.6 | | |
| BL 544/AL 644 | 709 - 355 - 44 | 22.5 | 29.1 | | |
| BL 546 | 709 - 355 - 46 | 27.0 | 33.7 | | |
| BL 566/AL 666 | 709 - 355 - 66 | 32.0 | 38.7 | | |
| BL 588/AL 688 | 709 - 355 - 88 | 42.5 | 49.3 | | |
| BL 623 | 709 - 307 - 23 | 20.0 | 30.7 | 7.92 | 3.2 |
| BL 634 | 709 - 307 - 34 | 27.0 | 37.7 | | |
| BL 644/AL 844 | 709 - 307 - 44 | 30.0 | 40.7 | | |
| BL 646 | 709 - 307 - 46 | 37.0 | 47.7 | | |
| BL 666/AL 866 | 709 - 307 - 66 | 43.0 | 53.7 | | |
| BL 688/AL 888 | 709 - 307 - 88 | 56.5 | 67.2 | | |
| BL 823 | 709 - 309 - 23 | 25.0 | 35.7 | 9.53 | 3.2 |
| BL 834 | 709 - 309 - 34 | 33.0 | 43.7 | | |
| BL 844/AL 1044 | 709 - 309 - 44 | 37.0 | 47.7 | | |
| BL 846 | 709 - 309 - 46 | 46.0 | 56.7 | | |
| BL 866/AL 1066 | 709 - 309 - 66 | 53.0 | 63.7 | | |
| BL 888/AL 1088 | 709 - 309 - 88 | 69.5 | 80.3 | | |
| BL 1023 | 709 - 311 - 23 | 30.0 | 42.4 | 11.1 | 4.0 |
| BL 1034 | 709 - 311 - 34 | 39.2 | 51.6 | | |
| BL 1044/AL 1244 | 709 - 311 - 44 | 44.2 | 56.6 | | |
| BL 1046 | 709 - 311 - 46 | 54.2 | 66.6 | | |
| BL 1066/AL 1266 | 709 - 311 - 66 | 63.2 | 75.6 | | |
| BL 1088/AL 1288 | 709 - 311 - 88 | 79.9 | 92.4 | | |
| BL 1223 | 709 - 312 - 23 | 34.5 | 46.9 | 12.7 | 4.0 |
| BL 1234 | 709 - 312 - 34 | 46.2 | 58.6 | | |
| BL 1244/AL 1444 | 709 - 312 - 44 | 50.0 | 64.4 | | |
| BL 1246 | 709 - 312 - 46 | 63.5 | 76.0 | | |
| BL 1266/AL 1466 | 709 - 312 - 66 | 75.3 | 87.8 | | |
| BL 1288/AL 1488 | 709 - 312 - 88 | 98.6 | 111.1 | | |
| BL 1423 | 709 - 314 - 23 | 38.7 | 51.1 | 14.27 | 4.0 |
| BL 1434 | 709 - 314 - 34 | 52.2 | 64.6 | | |
| BL 1444/AL 1644 | 709 - 314 - 44 | 58.6 | 71.1 | | |
| BL 1446 | 709 - 314 - 46 | 71.7 | 84.2 | | |
| BL 1466/AL 1666 | 709 - 314 - 66 | 85.1 | 97.7 | | |
| BL 1623 | 709 - 317 - 23 | 43.1 | 60.6 | | |
| BL 1634 | 709 - 317 - 34 | 58.0 | 75.5 | | |
| BL 1644 | 709 - 317 - 44 | 65.7 | 82.9 | | |
| BL 1646 | 709 - 317 - 46 | 79.9 | 97.4 | | |
| BL 1666 | 709 - 317 - 66 | 94.6 | 112.2 | | |
| BL 1688 | 709 - 317 - 88 | 124.0 | 141.6 | | |

Lacings

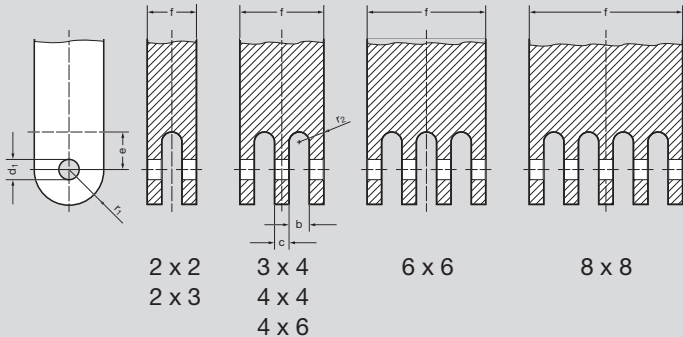

Recommendations for fastening block dimensions onto leaf chains (inner links)

| Chain No. | Inner link connector dimensions (in mm) | | | | | | |
|-----------------|---|--------|--------|---------------------|--------|---------------------|---------------------|
| | f max. | b min. | c max. | d ₁ D 10 | e min. | r ₁ max. | r ₂ max. |
| BL 422/AL 522 | 10.7 | 4.2 | – | | | | 2.0 |
| BL 423 | 12.6 | 6.4 | – | | | | 3.0 |
| BL 434 | 16.9 | 4.2 | 2.0 | | | | 2.0 |
| BL 444/AL 544 | 18.9 | 4.2 | 4.0 | 5.1 | 9.0 | 6.5 | 2.0 |
| BL 446 | 22.9 | 6.4 | 4.0 | | | | 3.0 |
| BL 466/AL 566 | 26.9 | 4.2 | 4.0 | | | | 2.0 |
| BL 488/AL 588 | 35.4 | 4.2 | 4.0 | | | | 2.0 |
| BL 522/AL 622 | 12.7 | 5.0 | – | | | | 2.0 |
| BL 523 | 14.9 | 7.5 | – | | | | 2.0 |
| BL 534 | 19.9 | 5.0 | 2.4 | | | | 2.0 |
| BL 544/AL 644 | 22.4 | 5.0 | 4.8 | 6.0 | 11.0 | 8.0 | 2.0 |
| BL 546 | 26.9 | 7.5 | 4.8 | | | | 2.0 |
| BL 566/AL 666 | 31.9 | 5.0 | 4.8 | | | | 2.0 |
| BL 588/AL 688 | 42.4 | 5.0 | 4.8 | | | | 2.0 |
| BL 623 | 19.9 | 10.3 | – | | | | 5.0 |
| BL 634 | 26.9 | 6.8 | 3.2 | | | | 3.0 |
| BL 644/AL 844 | 29.9 | 6.8 | 6.4 | | | | 3.0 |
| BL 646 | 36.9 | 10.3 | 6.4 | 8.0 | 14.0 | 9.5 | 5.0 |
| BL 666/AL 866 | 42.9 | 6.8 | 6.4 | | | | 3.0 |
| BL 688/AL 888 | 56.4 | 6.8 | 6.4 | | | | 3.0 |
| BL 823 | 24.9 | 12.8 | – | | | | 6.0 |
| BL 834 | 32.9 | 8.5 | 4.0 | | | | 4.0 |
| BL 844/AL 1044 | 36.9 | 8.5 | 8.0 | | | | 4.0 |
| BL 846 | 45.9 | 12.8 | 8.0 | 9.6 | 18.0 | 12.5 | 6.0 |
| BL 866/AL 1066 | 52.9 | 8.5 | 8.0 | | | | 4.0 |
| BL 888/AL 1088 | 69.4 | 8.5 | 8.0 | | | | 4.0 |
| BL 1023 | 29.8 | 15.1 | – | | | | 7.0 |
| BL 1034 | 39.0 | 10.0 | 4.7 | | | | 5.0 |
| BL 1044/AL 1244 | 44.0 | 10.0 | 9.4 | | | | 5.0 |
| BL 1046 | 54.0 | 15.1 | 9.4 | 11.2 | 22.0 | 15.0 | 7.0 |
| BL 1066/AL 1266 | 63.0 | 10.0 | 9.4 | | | | 5.0 |
| BL 1088/AL 1288 | 79.7 | 10.0 | 9.4 | | | | 5.0 |
| BL 1223 | 34.3 | 17.7 | – | | | | 8.0 |
| BL 1234 | 46.0 | 11.8 | 5.5 | | | | 5.0 |
| BL 1244/AL 1444 | 49.0 | 11.8 | 11.0 | | | | 5.0 |
| BL 1246 | 63.3 | 17.7 | 11.0 | 12.8 | 26.0 | 19.0 | 8.0 |
| BL 1266/AL 1466 | 75.1 | 11.8 | 11.0 | | | | 5.0 |
| BL 1288/AL 1488 | 98.4 | 11.8 | 11.0 | | | | 5.0 |
| BL 1423 | 38.5 | 20.1 | – | | | | 10.0 |
| BL 1434 | 52.0 | 13.4 | 6.3 | | | | 6.0 |
| BL 1444/AL 1644 | 58.4 | 13.4 | 12.6 | 14.3 | 31.0 | 22.0 | 6.0 |
| BL 1446 | 71.5 | 20.1 | 12.6 | | | | 10.0 |
| BL 1466/AL 1666 | 84.9 | 13.4 | 12.6 | | | | 6.0 |
| BL 1623 | 42.8 | 22.5 | – | | | | 10.0 |
| BL 1634 | 57.7 | 15.0 | 7.1 | | | | 7.0 |
| BL 1644 | 65.4 | 15.0 | 14.2 | | | | 7.0 |
| BL 1646 | 79.6 | 22.5 | 14.2 | 17.5 | 34.0 | 25.0 | 10.0 |
| BL 1666 | 94.3 | 15.0 | 14.2 | | | | 7.0 |
| BL 1688 | 123.7 | 15.0 | 14.2 | | | | 7.0 |

| Chain No. | Inner link connector dimensions (in mm) | | | | | | |
|-------------|---|--------|--------|---------------------|--------|---------------------|---------------------|
| | f max. | b min. | c max. | d ₁ D 10 | e min. | r ₁ max. | r ₂ max. |
| F 12 – 44 | 15.9 | | | | | | |
| F 12 – 66 | 22.9 | 3.5 | 3.0 | 4.5 | 7.3 | 6.5 | 1.7 |
| F 15 – 44 | 14.9 | | | | | | |
| F 15 – 66 | 21.9 | 3.5 | 3.0 | 5.1 | 8.5 | 8.0 | 1.7 |
| F 19 – 44 | 17.5 | | | | | | |
| F 19 – 66 | 24.6 | 4.1 | 3.6 | 5.75 | 10.0 | 9.5 | 1.7 |
| F 25 – 44 | 27.9 | | | | | | |
| F 25 – 66 | 40.9 | 6.7 | 6.2 | 8.3 | 13.5 | 13.0 | 3.0 |
| F 25 – 88 | 53.9 | | | | | | |
| F 31 – 44 | 32.9 | | | | | | |
| F 31 – 66 | 46.9 | 7.5 | 7.0 | 10.2 | 17.0 | 16.5 | 3.5 |
| F 31 – 88 | 61.9 | | | | | | |
| F 38 – 44 | 48.0 | | | | | | |
| F 38 – 66 | 69.0 | 11.0 | 10.0 | 14.7 | 22.0 | 20.0 | 5.0 |
| F 38 – 88 | 90.9 | | | | | | |
| F 44 – 22 | 29.5 | | | | | | |
| F 44 – 44 | 54.8 | | | | | | |
| F 44 – 66 | 80.0 | 13.0 | 12.0 | 16.0 | 25.0 | 24.0 | 6.0 |
| F 44 – 88 | 105.8 | | | | | | |
| F 50 – 22 | 34.2 | | | | | | |
| F 50 – 44 | 59.7 | | | | | | |
| F 50 – 66 | 86.2 | 13.6 | 12.6 | 17.9 | 28.0 | 27.0 | 6.0 |
| F 50 – 88 | 113.7 | | | | | | |
| F 63 – 22 | 39.6 | | | | | | |
| F 63 – 44 | 73.0 | | | | | | |
| F 63 – 66 | 106.3 | 17.0 | 16.0 | 23.0 | 35.0 | 35.0 | 8.0 |
| F 63 – 88 | 139.8 | | | | | | |
| F 76 – 44 | 91.2 | | | | | | |
| F 76 – 66 | 133.2 | 21.0 | 20.0 | 29.3 | 45.0 | 40.0 | 10.0 |
| F 76 – 88 | 173.9 | | | | | | |
| F 19 V – 44 | 22.9 | | | | | | |
| F 19 V – 66 | 32.9 | 5.2 | 4.7 | 6.6 | 10.0 | 10.5 | 2.0 |

For more information visit our website www.rexnord.eu

Fastening of leaf chains

End plates as inner links

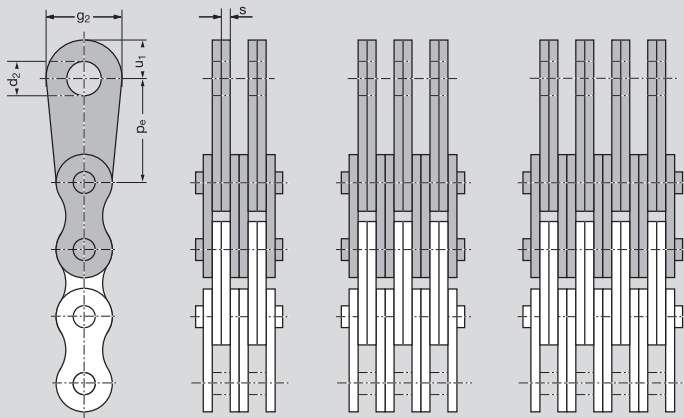

Scope of delivery:
End plate (pear-shaped) as well as leaf chain outer link supplied as complete sub-assembly for riveting.

End plates as outer links

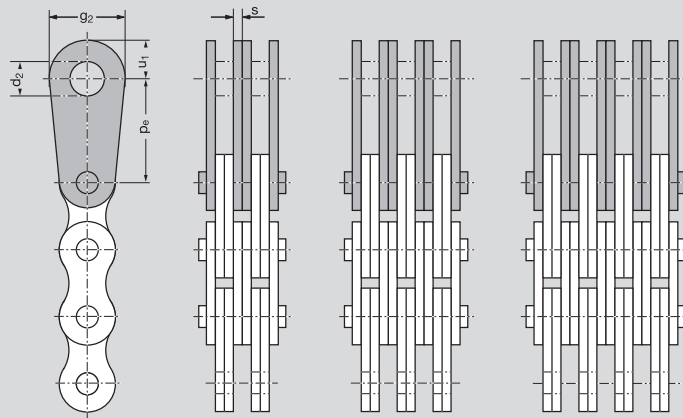

Scope of delivery:
End plate (pear-shaped) as well as corresponding rivet pin for riveting.

| Chain Order No. | End plates | | Dimensions (in mm) | | | | |
|-----------------|----------------|-----|--------------------|--------------------|----------------|------|----------------|
| | IEG | AEG | Pe | d ₂ A11 | g ₂ | s | u ₁ |
| F 12 - 44 | 170 - 112 - 44 | 45 | 15 | 6 | 16.0 | 1.7 | 10.0 |
| F 12 - 66 | 170 - 112 - 66 | 65 | | | | | |
| F 15 - 44 | 170 - 115 - 44 | 45 | 20 | 8 | 18.0 | 1.5 | 11.0 |
| F 15 - 66 | 170 - 115 - 66 | 65 | | | | | |
| F 25 - 44 | 170 - 124 - 44 | 45 | 30 | 12 | 25.0 | 3.0 | 15.0 |
| F 25 - 66 | 170 - 124 - 66 | 65 | | | | | |
| F 25 - 88 | 170 - 124 - 88 | 85 | | | | | |
| F 31 - 44 | 170 - 131 - 44 | 45 | 50 | 18 | 40.0 | 3.5 | 25.0 |
| F 31 - 66 | 170 - 131 - 66 | 65 | | | | | |
| F 31 - 88 | 170 - 131 - 88 | 85 | | | | | |
| F 38 - 44 | 170 - 138 - 44 | 45 | 65 | 24 | 50.0 | 5.0 | 29.0 |
| F 38 - 66 | 170 - 138 - 66 | 65 | | | | | |
| F 38 - 88 | 170 - 138 - 88 | 85 | | | | | |
| F 44 - 22 | 170 - 144 - 22 | 25 | 80 | 28 | 60.0 | 6.0 | 32.0 |
| F 44 - 44 | 170 - 144 - 44 | 45 | | | | | |
| F 44 - 66 | 170 - 144 - 66 | 65 | | | | | |
| F 50 - 22 | 170 - 150 - 22 | 25 | 90 | 32 | 70.0 | 6.3 | 43.0 |
| F 50 - 88 | 170 - 150 - 88 | 85 | | | | | |
| F 63 - 44 | 170 - 163 - 44 | 45 | 100 | 38 | 80.0 | 8.0 | 46.5 |
| F 63 - 66 | 170 - 163 - 66 | 65 | | | | | |
| AL 644 | 170 - 118 - 44 | 45 | 25 | 10 | 19.8 | 2.4 | 11.2 |
| AL 666 | 170 - 118 - 66 | 65 | | | | | |
| AL 688 | 170 - 118 - 88 | 85 | | | | | |
| AL 1044 | 170 - 130 - 44 | 45 | 40 | 14 | 30.0 | 4.0 | 18.0 |
| AL 1066 | 170 - 130 - 66 | 65 | | | | | |
| F 19 V 44 | 170 - 120 - 44 | 45 | 25 | 10 | 19.8 | 2.35 | 11.2 |
| F 19 V 66 | 170 - 120 - 66 | 65 | | | | | |

End plates are available as inner and outer links.

Example for ordering end plates for leaf chain F 38-44:

a) as IEG (inner Link): 170-138-44

b) as AEG (outer link): 170-138-45

Offset Sidebar Chains



Chains for drum drives

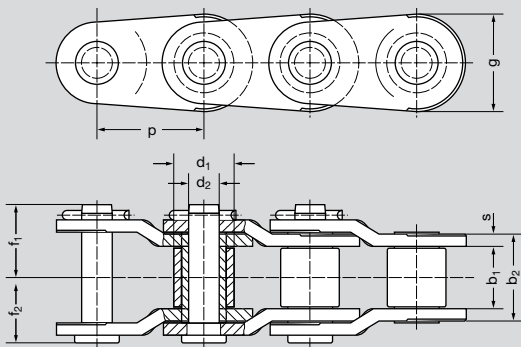

Type A

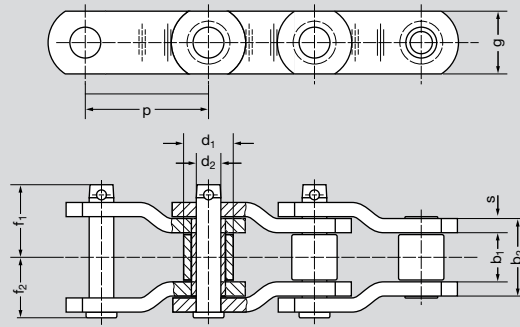

Type B

| Rex Chain No. | Chain No. | Pitch p | | Roller width b ₁ min. mm | Roller Ø d ₁ max. mm | Pin Ø d ₂ max. mm | Inner width b ₂ max. mm | Link plate height g mm | Link plate thick s mm | f ₁ mm | f ₂ mm | Bearing area A cm ² | Min. ultimate strength required*) acc. to DIN/ISO F _B N | Weight ≈ q kg/m | Type |
|----------------|----------------|---------|--------|--|------------------------------------|---------------------------------|---------------------------------------|---------------------------|--------------------------|-------------------|-------------------|-----------------------------------|--|--------------------|------|
| | | inch | mm | | | | | | | | | | | | |
| 3160 | Ro 20 | 2.0 | 50.8 | 30.56 | 28.58 | 14.27 | 44.7 | 48.0 | 6.35 | 37.6 | 33.9 | 6.4 | 222 500 | 9.9 | A |
| B 3113 | Ro 20 H | 2.0 | 50.8 | 30.56 | 28.58 | 15.06 | 47.6 | 41.5 | 8.0 | 41.3 | 38.1 | 7.1 | 231 400 | 10.9 | A |
| R 1035 | Ro 3 | 3.075 | 78.1 | 36.90 | 31.75 | 15.875 | 54.0 | 41.5 | 8.0 | 46.9 | 41.3 | 8.5 | 271 500 | 11.0 | B |
| 1037 | | 3.075 | 78.1 | 36.5 | 31.75 | 16.46 | 57.2 | 44.5 | 9.5 | 50.0 | 45.2 | 9.4 | 280 400 | 12.8 | B |
| AX 1568 | Ro 3 b | 3.067 | 77.9 | 38.5 | 41.28 | 19.05 | 58.8 | 57.5 | 9.5 | 53.2 | 46.1 | 11.2 | 400 500 | 18.0 | B |
| RX 238 | Ro 3 ½ | 3.5 | 88.9 | 36.9 | 44.45 | 22.22 | 63.5 | 57.5 | 12.7 | 61.2 | 52.8 | 14.1 | 556 300 | 23.6 | B |
| 1244 | Ro 4 | 4.063 | 103.2 | 48.0 | 44.45 | 22.22 | 74.6 | 54.0 | 12.7 | 66.7 | 58.4 | 16.6 | 476 200 | 19.4 | B |
| RX 1245 | Ro 4 b | 4.073 | 103.45 | 47.6 | 45.24 | 23.81 | 77.8 | 60.5 | 14.3 | 69.9 | 62.4 | 18.5 | 650 000 | 27.9 | B |
| Ro 635 | Ro 4 ½ | 4.5 | 114.3 | 50.8 | 57.15 | 27.78 | 81.0 | 76.5 | 14.3 | 71.5 | 65.1 | 22.5 | 894 500 | 32.9 | B |
| RX 1207 | Ro 5 b | 5.0 | 127.0 | 68.3 | 63.5 | 31.75 | 101.6 | 89.0 | 15.9 | 82.6 | 74.3 | 32.2 | 1 161 500 | 52.5 | B |
| Ro 1306 | Ro 6 | 6.0 | 152.4 | 74.6 | 76.2 | 38.1 | 114.3 | 102.0 | 19.0 | 97.7 | 84.6 | 43.5 | 1 646 500 | 67.1 | B |

*) Details about the effective higher Rexnord ultimate strengths and fatigue strength values are available upon request.

Laschenkette



For straddle carriers and other extreme demands

Laschenkette 64-1 S BG

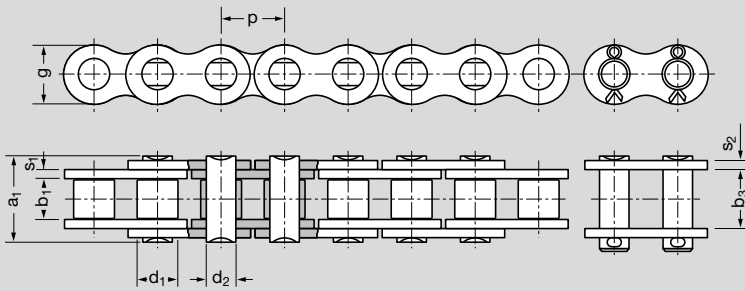

Dirt and grease on roller chains very often leads to the problem that oil cannot penetrate into the chain bearing surfaces. Under the same maintenance and lubrication conditions Laschenkette can be lubricated much more effectively compared to normal roller chains.

The distance that the lubricant has to travel to reach the pins is much shorter. The optimized clearances also help to eliminate corrosion problems (no pitting corrosion on pins).

Rexnord Laschenkette are used primarily for lifting purposes on straddle carriers. The main feature in this new development in chains is the elimination of service-life critical chain bushings and the optimisation of the remaining chain components.

Two main features are:

- doubling the movable plates
- stronger pins with additional 50 % larger surface area and 85 % larger sectional modulus.

Practical tests of Laschenkette on straddle carriers in several ports and on test stands have shown a 3 to 5-times longer working life that the standard roller chain version.

Laschenkette RLK 50-1 SL/A, Laschenkette 64-1 S / SH / SH BK

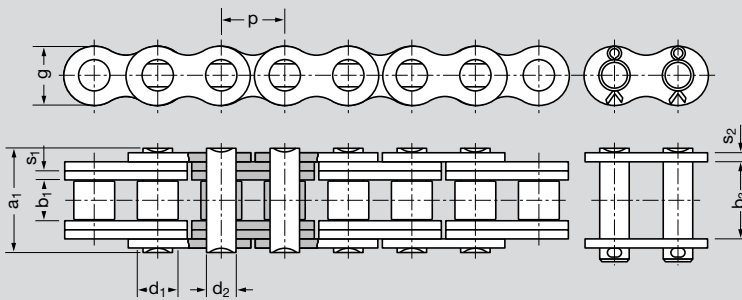

Laschenkette RLK 50-2 SL/A

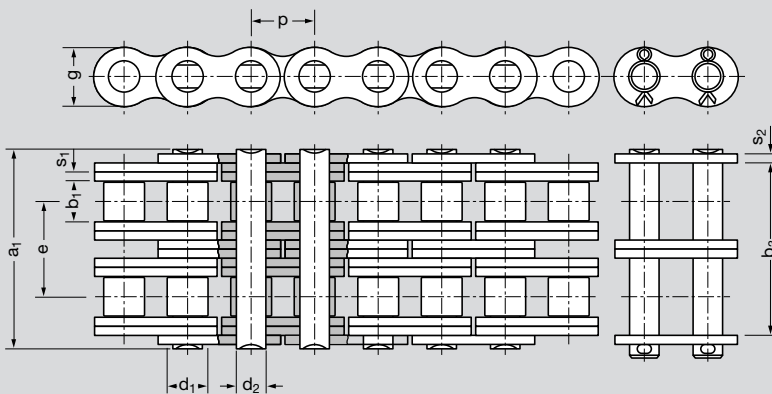

Technical Data

| Chain No. | Pitch p | | Roller width b ₁ min. mm | Roller Ø d ₁ max. mm | Pin Ø d ₂ max. mm | Pin link width b ₃ min. mm | Transverse e mm | Link plate height g mm | Pin length a ₁ max. mm | Link plate thick | | Bearing area A cm ² | Approx. ultimate strength F _B N | Weight ≈ q kg/m |
|-------------|---------|------|---|---------------------------------------|------------------------------------|---|-----------------------|------------------------------|---|----------------------|----------------------|--------------------------------------|--|-----------------------|
| | inch | mm | | | | | | | | s ₁ mm | s ₂ mm | | | |
| 50 – 1 SL/A | 2.00 | 50.8 | 31.55 | 28.58 | 20.35 | 57.5 | – | 47.8 | 75.5 | 6.3 | 6.3 | 5.1 | 270 000 | 14.9 |
| 50 – 2 SL/A | 2.00 | 50.8 | 31.55 | 28.58 | 20.35 | 128.0 | 70.5 | 47.8 | 146.0 | 6.3 | 6.3 | 10.2 | 540 000 | 29.4 |
| 64 – 1 S | 2.50 | 63.5 | 38.1 | 39.38 | 30.0 | 77.0 | – | 59.5 | 104.0 | 9.5 | 9.5 | 11.4 | 530 000 | 28.0 |
| 64 – 1 SBG | 2.50 | 63.5 | 39.1 | 39.38 | 30.0 | 59.0 | – | 59.5 | 83.0 | 9.5 | 8.0 | 5.7 | 450 000 | 27.9 |
| 64 – 1 SH | 2.50 | 63.5 | 38.1 | 39.38 | 30.0 | 71.5 | – | 59.5 | 103.0 | 8.0 | 12.0 | 9.6 | 650 000 | 27.0 |
| 64 – 1 SHBK | 2.50 | 63.5 | 27.6 | 39.38 | 30.0 | 67.0 | – | 59.5 | 97.0 | 9.5 | 12.0 | 11.4 | 650 000 | 28.0 |

Construction of the Laschenkette

Laschenkette is constructed in a similar way to leaf chain (plates and pins only). In a lifting application the wear resistance and reliability of laschenkette and leaf chain are therefore comparable. The high-wearing component of the roller chain, the bushing, is not used in Laschenkette. The rollers are fitted directly onto the pins which are larger in diameter.

This improved interaction between chain and sprocket also benefits the synchronisation of lifting in straddle carriers.

Advantages in practical applications

- fewer chain replacements through a 3 to 5-times longer working life.
- lower costs because fewer chain sets are required.
- reduction in downtimes.
- higher operational safety by calculating time for replacements.

Marine Diesel roller chains

Highest service reliability - achieved by optimum fatigue resistance



Original Rexnord roller link plate with new design

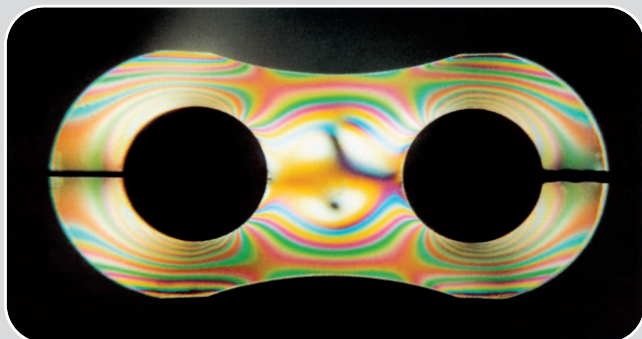

Optical illustration of stress lines

The shape of the newly-designed "Rexnord inner link plate" results in the largest possible fatigue resistance value with consideration made for the limiting values of link plate height as well as the other constructional parameters such as thickness, eccentric profile of the link plate head, material strength and production methods.

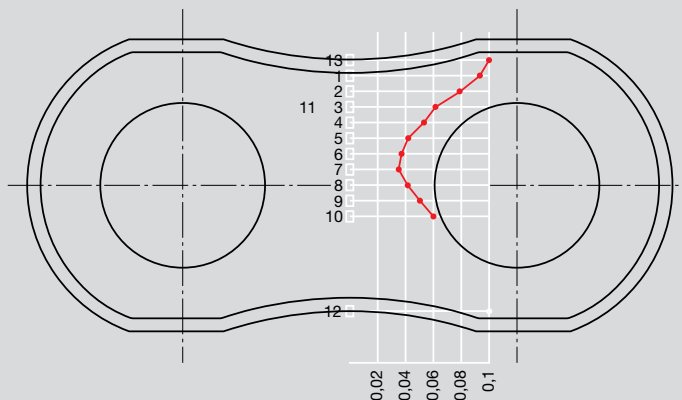

Measurement of tension in the link plate using a wire strain gauge

Rexnord research findings

The plate of the inner link is the specific part of a roller chain which determines the fatigue resistance and in consequence the operational safety of the complete roller chain.

Only a chain with the highest fatigue resistance guarantees a trouble-free working life.

In the case of marine diesel roller chains, operational safety is the most important factor overall. As a result of extensive research and development, Rexnord has developed a new plate design which increases the fatigue resistance by more than 30%.

Full stress analysis has been carried out to balance the link plate height limitation with the cross-section and the increase in length in the link plate head.

Assembly of the connecting link

Easy assembly and joining of chains is possible with the inclusion of a shoulder on the connecting pin and use of a soft pin end.

Note:

Marine diesel roller chains could also be considered for use on critical drives in industrial applications. They would be particularly advantageous in drives operating at the limits of standard roller chains, as well as those drives requiring high efficiency and reliability, but especially to replace chain drives susceptible to fatigue fractures.

Roller chains, single-strand ISO 606 / DIN 8187 (marine diesel)

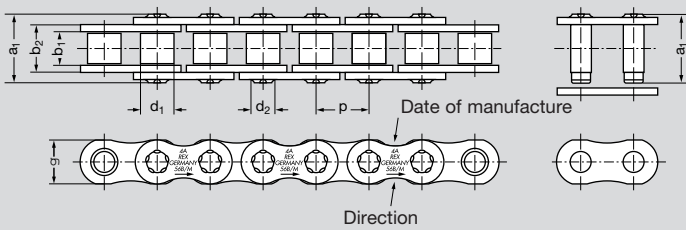

| Chain No. | Pitch p | | Roller width b ₁ min. mm | Roller Ø d ₁ max. mm | Pin Ø d ₂ max. mm | Inner width b ₂ max. mm | Link plate high g mm | Transverse e mm | Pin length a ₁ max. mm | Bearing Area A cm ² | Min. ultimate strength required*) acc. to DIN/ISO F _B N | Weight ≈ q kg/m |
|-------------------|---------|-------|---|---------------------------------------|------------------------------------|--|----------------------------|-----------------------|---|--------------------------------------|---|-----------------------|
| | inch | mm | | | | | | | | | | |
| 40 B - 1 M | 2.50 | 63.5 | 38.1 | 39.37 | 22.89 | 55.7 | 55.3 | – | 82.6 | 12.75 | 355 000 | 17.0 |
| 48 B - 1 M | 3.00 | 76.2 | 45.72 | 48.26 | 29.24 | 70.5 | 65.3 | – | 98.5 | 20.63 | 560 000 | 26.0 |
| 56 B - 1 M | 3.50 | 88.9 | 53.34 | 53.98 | 34.32 | 81.3 | 80.3 | – | 114.0 | 27.9 | 850 000 | 37.0 |
| 64 B - 1 M | 4.00 | 101.6 | 60.96 | 63.5 | 39.4 | 92.0 | 93.3 | – | 130.0 | 36.25 | 1 120 000 | 50.0 |
| 72 B - 1 M | 4.50 | 114.3 | 68.58 | 72.39 | 44.5 | 103.0 | 105.3 | – | 147.0 | 46.19 | 1 400 000 | 65.0 |

Roller chains, double-strand ISO 606 / DIN 8187 (marine diesel)

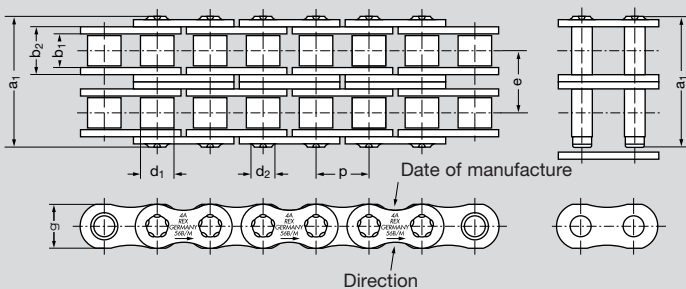

Note:

If multiple strands of single chains are used in the same drive, then all strands must be delivered as a matched pair or group, and are adjusted according to Rexnord standards in the factory. Please indicate choice when ordering.

| Chain No. | Pitch p | | Roller width b ₁ min. mm | Roller Ø d ₁ max. mm | Pin Ø d ₂ max. mm | Inner width b ₂ max. mm | Link plate high g mm | Transverse e mm | Pin length a ₁ max. mm | Bearing Area A cm ² | Min. ultimate strength required*) acc. to DIN/ISO F _B N | Weight ≈ q kg/m |
|-------------------|---------|-------|---|---------------------------------------|------------------------------------|--|----------------------------|-----------------------|---|--------------------------------------|---|-----------------------|
| | inch | mm | | | | | | | | | | |
| 40 B - 2 M | 2.50 | 63.5 | 38.1 | 39.37 | 22.89 | 55.7 | 55.3 | 72.29 | 154.0 | 25.5 | 630 000 | 34.0 |
| 48 B - 2 M | 3.00 | 76.2 | 45.72 | 48.26 | 29.24 | 70.5 | 65.3 | 91.21 | 190.0 | 41.23 | 1 000 000 | 53.0 |
| 56 B - 2 M | 3.50 | 88.9 | 53.34 | 53.98 | 34.32 | 81.3 | 80.3 | 106.6 | 221.0 | 55.8 | 1 600 000 | 74.0 |
| 64 B - 2 M | 4.00 | 101.6 | 60.96 | 63.5 | 39.4 | 92.0 | 93.3 | 119.89 | 250.0 | 72.5 | 2 000 000 | 98.0 |
| 72 B - 2 M | 4.50 | 114.3 | 68.58 | 72.39 | 44.5 | 103.8 | 105.3 | 136.27 | 283.0 | 92.4 | 2 500 000 | 128.0 |

*) Details about the effective higher Rexnord ultimate strengths and fatigue strength values are available upon request.

Matching of timing roller chains

If 2 or more chains for the same drive are being used, then an exact matching of chains is of utmost importance. The Rexnord method of matching of individual chain length and selective composition of these lengths ensures extremely high precision over the complete chain length.

The use of Rexnord chains guarantees an even load distribution between chains and sprockets. Rexnord chain-matching meets all requirements of all engine manufacturers.

Rexnord- the quality standard for marine diesel roller chains!

- All Rexnord chain parts are shot-peened.
- Rexnord link plate bores are produced to very high tolerances and surface finish.
- Rexnord chain pins and bushings are especially wear-resistant due to outstanding case depth hardness
- Rexnord chains are pre-loaded.
- Rexnord chain rollers have a high strength because they are through-hardened and manufactured from high-precision seamless tubes.
- Rexnord chains are often referred to as "A chain with pedigree".
- Rexnord chains are precision-manufactured, resulting in an even load distribution.
- Rexnord offers a complete quality assurance in each and every production step.
- Rexnord marine diesel roller chains possess an outstanding fatigue strength and thereby an optimum operational safety.

Fastening dimensions for roller chains, European and American standard

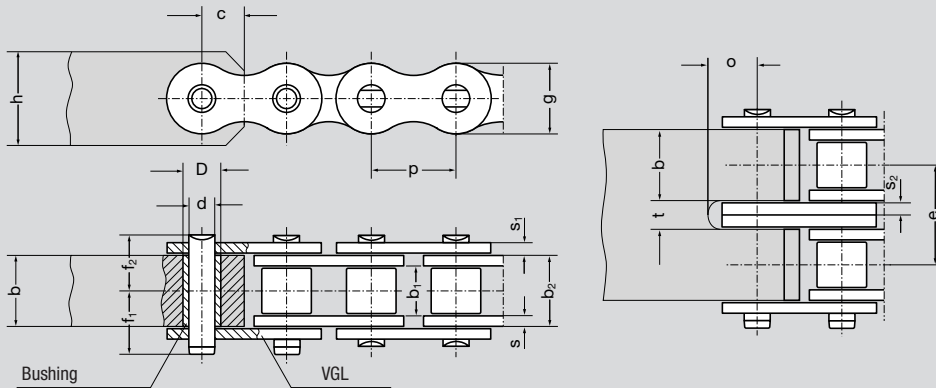

The material strength of the fastening units must be at least 490 N/mm². If there is to be pivoting movement at the fastening point, then Rexnord recommends fitting the fastening unit with a bush. It possesses a surface hardness of ca. 60 HRc and considerably increases the resistance to wear.

Normal static loads do not require a hardened bushing. These bushes can be supplied by Rexnord. Please quote the bush part No. when ordering. When inserting a bush into a D^{S7} bore, the bore of the bush becomes a d^{C10}. If no bush is inserted then the bore d^{C10} is brought directly into the fastening unit.

Fastening dimensions for roller chains, European standard, ISO 606 / DIN 8187

| ISO No. | Pitch p | | Roller width | | Inner width | | Link plate thick | | | | | | | Drilling-∅ | | | | Bushing part No. | |
|---------|---------|--------|------------------------|------------------------|-------------|-------------------|-------------------|------|-------|-------------------|-------------------|------|-----------|------------|---------------------|--------------------|------|------------------|--------|
| | inch | mm | b ₁ min. mm | b ₂ max. mm | s mm | s ₁ mm | s ₂ mm | g mm | e mm | f ₁ mm | f ₂ mm | h mm | b max. mm | c mm | d ^{C10} mm | D ^{S7} mm | t mm | | o mm |
| 08 B | 0.50 | 12.7 | 7.75 | 11.3 | 1.7 | 1.7 | 1.25 | 11.6 | 13.92 | 10.3 | 8.4 | 11 | 11.2 | 6.0 | 4.45 | 6.27 | 2.7 | 7.5 | 001544 |
| 10 B | 0.625 | 15.875 | 9.65 | 13.28 | 1.7 | 1.5 | 1.5 | 14.6 | 16.59 | 11.3 | 9.4 | 13 | 13.2 | 7.5 | 5.08 | 7.0 | 3.2 | 8.0 | 001543 |
| 12 B | 0.75 | 19.05 | 11.68 | 15.62 | 1.8 | 1.8 | 1.8 | 15.9 | 19.46 | 13.2 | 11.1 | 16 | 15.6 | 10.0 | 5.72 | 8.4 | 3.8 | 9.5 | 001542 |
| 16 B | 1.00 | 25.4 | 17.02 | 25.4 | 3.75 | 3.05 | 3.05 | 20.5 | 31.88 | 21.6 | 17.7 | 20 | 25.4 | 14.0 | 8.28 | 11.7 | 6.4 | 13.0 | 001541 |
| 20 B | 1.25 | 31.75 | 19.56 | 29.0 | 4.5 | 3.5 | 3.5 | 25.7 | 36.45 | 24.1 | 20.2 | 26 | 29.0 | 16.5 | 10.19 | 14.0 | 7.4 | 16.5 | 001449 |
| 24 B | 1.50 | 38.1 | 25.4 | 37.9 | 5.8 | 5.0 | 5.0 | 33.0 | 48.36 | 31.6 | 26.9 | 33 | 37.9 | 19.5 | 14.63 | 18.99 | 10.6 | 20.0 | 001540 |
| 28 B | 1.75 | 44.45 | 30.99 | 46.5 | 6.5 | 5.5 | 6.0 | 37.0 | 59.56 | 36.6 | 31.6 | 36 | 46.5 | 23.0 | 15.90 | 21.64 | 12.6 | 24.0 | 001539 |
| 32 B | 2.00 | 50.8 | 30.99 | 45.5 | 6.3 | 6.3 | 6.3 | 41.2 | 58.55 | 38.4 | 32.5 | 42 | 45.5 | 27.0 | 17.81 | 23.12 | 13.2 | 27.0 | 001538 |
| 40 B | 2.50 | 63.5 | 38.1 | 55.7 | 8.5 | 8.0 | 8.0 | 51.5 | 72.29 | 47.5 | 39.4 | 52 | 55.7 | 35.0 | 22.89 | 29.18 | 16.6 | 35.0 | 017776 |
| 48 B | 3.00 | 76.2 | 45.72 | 70.5 | 12.0 | 10.0 | 10.0 | 63.5 | 91.21 | 56.0 | 49.2 | 64 | 70.5 | 40.0 | 29.24 | 37.9 | 20.6 | 40.0 | 001535 |
| 56 B | 3.50 | 88.9 | 53.34 | 81.3 | 13.6 | 12.0 | 12.0 | 77.0 | 106.6 | 64.8 | 57.8 | 77 | 81.3 | 45.0 | 34.32 | 43.5 | 25.0 | 51.0 | 001536 |

Fastening dimensions for roller chains, American standard, ISO 606 / DIN 8188

| ANSI No. | Pitch p | | Roller width | | Inner width | | Link plate thick | | | | | | | Drilling-∅ | | | | Bushing part No. |
|----------|---------|--------|------------------------|------------------------|-------------|-------------------|------------------|-------|-------------------|-------------------|------|-----------|------|---------------------|--------------------|------|------|------------------|
| | inch | mm | b ₁ min. mm | b ₂ max. mm | s mm | s ₁ mm | g mm | e mm | f ₁ mm | f ₂ mm | h mm | b max. mm | c mm | d ^{C10} mm | D ^{S7} mm | t mm | o mm | |
| 40 | 0.50 | 12.7 | 7.85 | 11.15 | 1.5 | 1.5 | 11.6 | 14.38 | 11.2 | 8.1 | 11 | 11.1 | 6.0 | 3.96 | 5.98 | 3.2 | 7.0 | 001662 |
| 50 | 0.625 | 15.875 | 9.4 | 13.8 | 2.0 | 2.0 | 14.6 | 18.11 | 12.0 | 10.2 | 13 | 13.8 | 7.7 | 5.08 | 7.65 | 4.2 | 9.0 | 001523 |
| 60 | 0.75 | 19.05 | 12.57 | 17.7 | 2.4 | 2.4 | 17.6 | 22.78 | 14.4 | 12.8 | 16 | 17.6 | 9.0 | 5.94 | 9.0 | 5.0 | 10.0 | 001522 |
| 80 | 1.00 | 25.4 | 18.75 | 22.5 | 3.05 | 3.05 | 23.5 | 29.29 | 20.4 | 16.5 | 22 | 22.3 | 12.0 | 7.92 | 11.67 | 6.8 | 14.0 | 001521 |
| 100 | 1.25 | 31.75 | 18.98 | 27.4 | 4.0 | 4.0 | 28.7 | 35.76 | 23.7 | 19.7 | 26 | 27.4 | 15.5 | 9.53 | 13.82 | 8.4 | 17.5 | 001520 |
| 120 | 1.50 | 38.1 | 25.22 | 35.3 | 4.7 | 4.7 | 34.4 | 45.44 | 30.0 | 24.9 | 30 | 35.2 | 18.5 | 11.10 | 16.13 | 9.8 | 20.0 | 001519 |
| 140 | 1.75 | 44.45 | 25.22 | 37.0 | 5.5 | 5.5 | 40.8 | 48.87 | 31.6 | 26.7 | 36 | 37.0 | 21.5 | 12.70 | 18.29 | 11.6 | 23.5 | 001518 |
| 160 | 2.00 | 50.8 | 31.55 | 45.0 | 6.3 | 6.3 | 47.8 | 58.55 | 36.4 | 31.8 | 42 | 44.7 | 24.0 | 14.27 | 20.7 | 13.2 | 27.5 | 001517 |
| 180 | 2.25 | 57.15 | 35.72 | 50.5 | 7.0 | 7.0 | 54.0 | 65.35 | 41.4 | 35.7 | 47 | 50.6 | 27.0 | 17.46 | 25.35 | 14.6 | 32.0 | 001516 |
| 200 | 2.50 | 63.5 | 37.85 | 54.7 | 8.0 | 8.0 | 60.0 | 71.55 | 45.0 | 39.0 | 52 | 54.6 | 30.0 | 19.84 | 28.38 | 16.6 | 34.5 | 001515 |
| 240 | 3.0 | 76.2 | 47.35 | 67.5 | 9.5 | 9.5 | 70.0 | 87.83 | 55.5 | 47.4 | 62 | 67.5 | 37.0 | 23.8 | 34.28 | 19.6 | 41.0 | 001514 |

Lubrication and maintenance of Rexnord chains

Operational safety and working life with effective lubrication

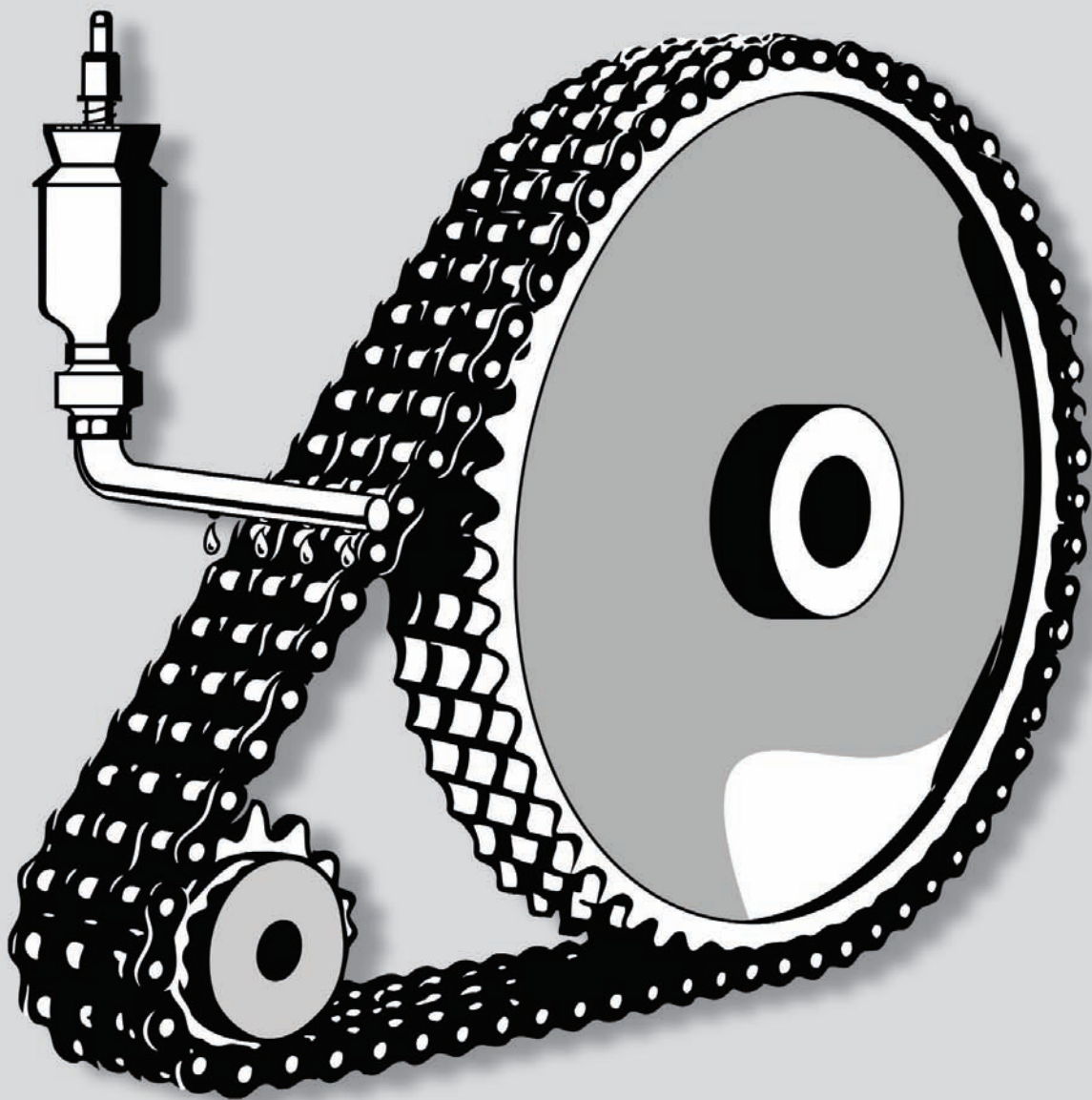

Ex-Works Lubrication

1. Standard Preservation - increased corrosion protection

As a result of drastically increased demands for increased environmental compatibility, Rexnord as a matter of principle now uses the newly-developed chain preservation **VSK 001** on nearly all chains supplied to customers. The advantages for the chain industry with this new standard preservation are:

- considerably improved corrosion protection
- improved wear protection characteristics
- environmental compatibility corresponds to the strict prerequisites for the environmental management certificate acc. to DIN EN ISO 14001 and the environmental stipulations of leading manufacturers
- suitable for use in the food industry, where direct contact with the product is not permitted. RexPro is registered by the NSF (National Sanitary Foundation) in the category H2
- suitable for use in the electrical and electronics industry. RexPro conforms to RoHS
- anti-drip security in surrounding temperatures of up to +50°C
- Evenly-spread film thickness (less danger of over-lubrication, more even-wear and corrosion protection)
- application temperature range varies between ca. -30°C and +130°C

Special lubrication products

For special demands, Rexnord can equip the chains with special lubricants for special applications.

These special lubricants are applied immediately after chain assembly, to guarantee good penetration into the chain joints. Chains from stock - these already have the usual preservation - are naturally not suitable for the application of these special products. To avoid long delivery times, it is strongly advisable to order these chains in good time.

2. Long-life lubrication

For use in areas which require high speeds, e.g. in packaging and timber processing machines as well as conveyors, the best and most suitable is the "long-life" **VSK 006**.

This product is a mineral oil-based special lubricant with the looks and viscosity of honey (please do not taste it!). STRUCTOVIS contains a special adhesion enhancer, so that the danger of soiling the transported goods through droplets or thrown-off oil by rapid running chains is drastically reduced or totally avoided. It has good wear and corrosion-resistance properties. STRUCTOVIS can be used in temperatures from ca. 0°C up to +120°C.

3. Wax lubrication

For use in areas with a dusty environment e.g. packaging, paper or textile machines as well as applications in the foodstuffs industry- the ideal wax lubricant is **VSK 018** (for rust- and acid-resistant chains VSK 019).

This lubricant has a list of special product features:

- non-drip
- grip-dry surface
- wax structure
- generally safe to water
- licensed foodstuffs lubricant with NSF H1 registration
- long-life product
- wear protection

The application temperature range reaches from ca. -40°C up to +120°C.

The product can be applied overall, where from time to time technically unavoidable contact with foodstuffs is made.

Furthermore, the wax is a good protector against corrosion. Testing in an atmospheric chamber with condensing water and changeable climate (DIN 50 017 KFW) showed a corrosion level of 0 after 30 cycles (= 720 hrs.). This corresponds to the performance of high-quality rust protective material. It provides astounding protection against friction, wear and tribo-corrosion.

4. Lubricating oil for the food industry

VSK 016 has found use as a lubricating oil for the foodstuffs industry, possessing the NSF H1 registration. It is ideally suited for use in the temperature range from ca. -25°C up to +120°C.

This product complies with the German Food Law and Commodity Goods Law (LFGB) and fulfils the demands of the "Guidelines of sec. 21 CFR 178.3570 of FDA Regulations".

This oil, specially conceived for application in the food industry, displays good wear protection and EP characteristics as well as a good behaviour in the cold.

In addition to its corrosion protection, 4 UH 1-1500 also offers a very good stability against ageing and oxidation.

5. High and low temperature lubrication

For temperature ranges between -40°C and +220°C, the product to recommend is **VSK 012**.

This can be used for chains working in sub-zero temperatures, such as e. g. in lifting gear in cold storage warehouses as well as on machines in open air conditions.

On the other hand, it can also be used in high temperature environments, e.g. chains in furnaces and drying equipment. This thermically stable synthetic oil contains special solid lubricant with emergency-running features.

6. High temperature lubrication

For high temperature ranges up to 250°C the product to recommend is **VSK 014** Special adhesion improves prevent the oil being thrown off the lubrication point. The few residues created by synthetic constituents are easy to regenerate by adding fresh oil.

Caused due to the favorable viscosity-temperature properties safe cold starts are possible.

This Oil is predominantly used in drying chambers, textile- and plastic machines, because it has good behaviors against wear at high temperatures.

For temperature ranges between 0°C and +400°C with dry lubricating effect, a suitable product here is **VSK 008**. It contains a package of solid lubricating components such as Molybdenum disulphide. These form a dry "greasy" film following evaporation above +180°C, which remains "greasy" up to temperatures of +400°C. Useful temperature range. ca. -50° up to +180°C, i.e. lubricating up to +400°C (dry lubrication).

Note

A large percentage of all application problems are covered by the aforementioned products. In addition to this list of lubricants, Rexnord offers a further range of special solutions. Furthermore, there are isolated cases in which special questions arise concerning follow-up lubrications. If the need should arise, then get in contact with the Rexnord application consultants, who will listen to all your questions about lubrication and provide informative answers.

Rexnord Application Consulting

Rexnord application consulting has at its disposal many years of all-round experience - not only on the side of practical deployment on site, but also through the large number of examinations and tests in their own research laboratory - this makes it possible to offer you optimum solutions for your application.

Make use of this advantage.

Lubrication of roller chains

Standard preservation - Increased corrosion protection

Simple and unproblematic as the lubrication of drive chains may appear, blame is laid on the user for a large number of mistakes, miscalculation or lack of knowledge, documented by the large percentage of chain defects which can be traced back to lubrication errors. The following text looks at the most common lubrication errors, their causes and the consequences, trying to develop a direction towards optimum chain lubrication.

Lubrication faults

The wearing life of a chain is largely dependent on the lubrication. Unfortunately even today, incorrect lubrication and badly-applied lubricating products that have a counter-productive effect on lubrication - the result being high wear and then premature failure. Statistics have shown that ca. 60 % of all chain defects are traced back to the wrong lubrication. In the past years, the availability of chain lubricants in spray cans has measurably increased- the problem is most of these spray cans contain a thinner, which evaporates after application leaving behind a tough, viscous non-flowing film of lubricant. Products with the same effect for the chain lubrication are also on offer, but in different forms and containers.

Lubrication practice

In practice, these thickening non-liquid lubricants achieve the formation of a lube film inside the chain joints at the first re-lubrication, because at this point in time the gaps are free for the lubricating product - between the side plates. Later lubrication processes only cause additional layers of grease to collect on the surface of the previous lubrication layer, which in the meantime has collected dirt particles, further viscosity and crusting. In the chain joints themselves, it is now no longer possible for the lubricant to penetrate inwards. The outward appearance of the chain - as is mostly advertised on the can by the maker - gives the user of the corresponding product the appearance of an impression that optimum lubrication has taken place. More than often the opposite is the case.

**The diagram says it all:
It is up to you to achieve a
60-fold, a 12-fold or an only
inadequate working life
from your chain.**

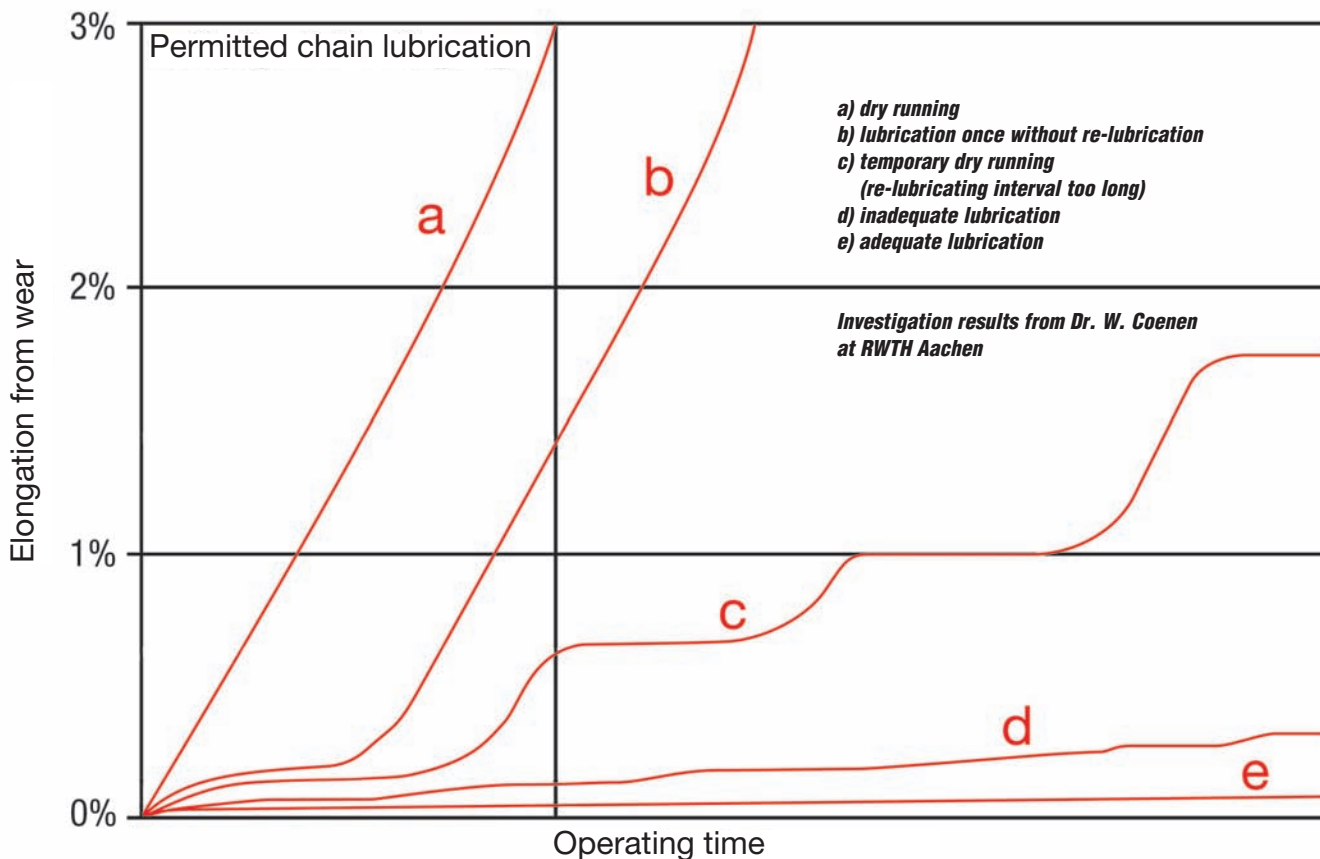

Lubrication check-up

Checking the effectiveness of the lubricant applied can be carried out easily by checking the pin of the connecting link. A thoroughly lubricated chain pin should have a lubrication film on the whole surface and the load-side surface should shine like a mirror after removing the lubricant.

If lines or even rust appear, then this is evidence of incorrect lubrication. A further indication of poor lubrication is a stiffening of certain chain links and they are not able to return to a straight line when under load.

Consequences of poor lubrication

The use of unsuitable lubricants which under normal conditions are too viscous to enter the chain joints cause dry friction. Furthermore this friction causes the formation of cavities, which then fill with condensed water in due course of time. Frictional and surface corrosion caused by the condensed water are the inevitable consequences.

Premature chain failures

New chains have very little play between pin and bush so corrosion leads to pitting and eventually seizure of the joints.

In a first stage the chain joints become stiff, where the pin seizes together with the bushing, destruction of the press-fit between pin and plate results, i.e. the roller link rotates the pin in the outer plate and destroys the critical press-fit. This leads to premature failure.

Premature wear

In less serious cases rapid elongation will happen as a result of dry running and oxidation- the signs of this are to be seen as the phenomenon known as "bleeding" where abrasive red oxide particles form and emerge from within the bearing areas.

Criteria for optimum chain lubrication

Demands on the lubricant

To achieve effective lubrication, it is necessary that at each application, enough quantities of liquid lubricant can penetrate into the chain joints.

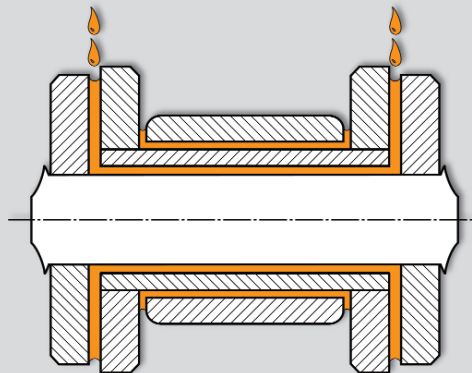

Fig. 2: Cross-section of a chain link

The chain link shown graphically in **fig. 2** shows clearly that the lubricating product has to pass through a narrow gap between the plates, to be able to penetrate into the joints with pins and bushes. Chain roller lubricant consumption is relatively small. Care must however be taken that the oil is applied to the edges of the plates.

Lubricant

A thin mineral, machine, or even motor or gear oil should always to be used.

Viscosity

The viscosity of the lubricant should be chosen so that it will remain fluid at all operating ambient temperatures. Here, the following oil viscosities of SAE 20 up to SAE 50 i.e. from 50 to 300 ISO VG at +40°C are to be recommended.

The products from Rexnord for chain lubrication remain capable of flowing even after application and still have special lubricating characteristics. They offer an optimum solution where demands require manual lubrication.

Rexnord High Performance Chain Spray "REXOIL" is purposely designed for this task for hard-working chain drives and lifting chains.

Lubrication methods

Manual lubrication

Chain drives with a speed of up to ca. 0.5 m/s can be lubricated manually. In this case the oil can be applied with a brush (**fig. 3**), oil can or spray can (**fig. 4**), which should contain a thin, well-flowing lubricant.

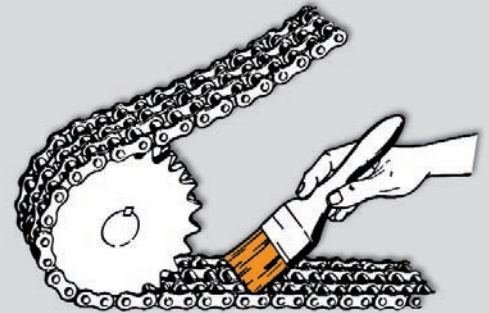

Fig. 3: Chain lubrication by brush

Rexnord has developed a new high performance chain spray. The lubricant used fulfils all normal demands made today.

The water-displacing characteristic, good adhesion and outstanding corrosion protection make this product a must for chains that work in the open air such as lifting chains in fork-lift trucks.

**Certified acc. to
USDA-H 2 for the
food-producing
industry**

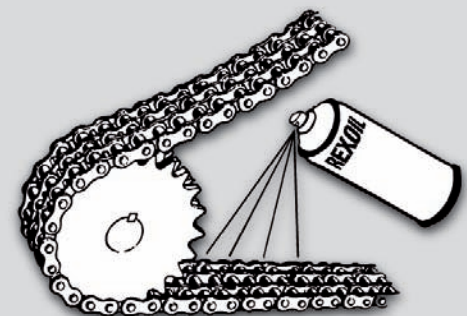

Fig. 4: Chain lubrication by spray can

Drip lubrication

Chain speeds between 0.5 and 1.5 m/s are best-suited for drip lubrication, **fig. 6**. Application of the oil is to the upper side of the chain plates as shown in fig. 6.

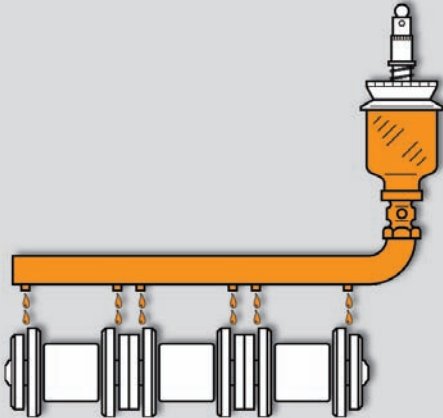

Fig. 6: Drip lubrication

Oil bath lubrication

Chain speeds from 1,5 up to 8 m/s need oil bath lubrication, **fig. 7**. For speeds between 4 to 8 m/s an oil-stirring disc should be installed next to the sprocket and only this disc should be immersed in the oil to avoid foaming.

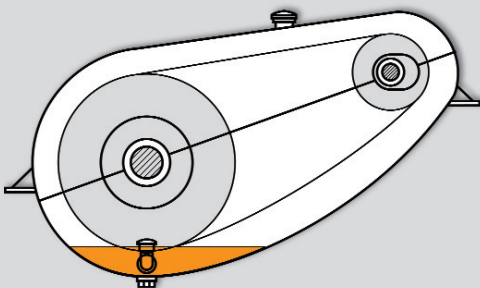

Fig. 7: Oil bath lubrication

Optimum cleaning of chains

If a chain has become so soiled externally that penetration of lubricating oil is no longer possible then cleaning the chain is unavoidable. This must be carried out using paraffin derivatives such as diesel-fuel, petroleum, cleaner's naphtha etc.

Here is a warning against the use of steam cleaners, the use of cold cleansing agents or even caustic and acidic agents. These can lead to direct chain damage.

Rexnord high performance chain spray is FCKW and CPC-free and is therefore classified as environmentally-friendly.

The continuous lubricant applicator guarantees a portioned oil application and enables an easy, dependable, economical and environmentally-friendly lubrication of the chain.

Summary

Finally, it should be mentioned that the most important function of chain lubrication is to provide adequate lubrication in the joints. Only thin oils can ensure the required dosage. Larger chains - as from 1fi" pitch and upwards - require volumes of lubricant not normally available from spray cans. Greases and oils which thicken after application should not be used.

Comments about the correct choice of chain

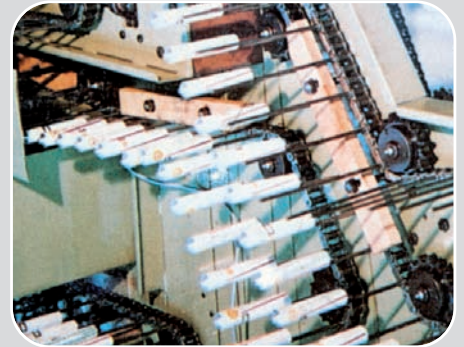
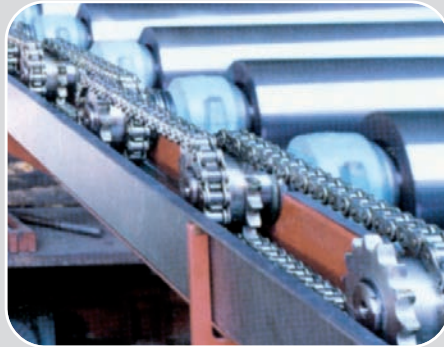
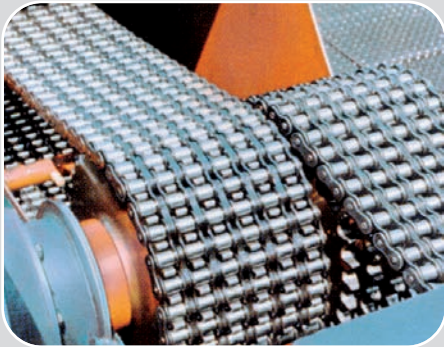

Decisive factors for the correct choice of chain are the values for the link surface pressure and the fatigue strength. The link surface pressure is the most important influential parameter for the wear-working life. The fatigue strength on the other hand determines whether the chain is absolutely operationally safe during its total wearing working life.

The tensile strength has no real significance in deciding the suitability of a chain for a particular application. It is more concerned with a statically determined value, during which however a chain undergoes dynamic loading situations in practice. The "Safe answer" to a dynamic loading can really only be the fatigue strength.

The calculation of the safety of a chain round and about the tensile strength and a safety factor of, say 3.5 or higher - leads in all cases to an over or under-dimensioning. A chain is only then correctly chosen with "certainty", when its fatigue strength is the same or is larger than the loading.

The trouble is that fatigue strength is in no way mathematically related to tensile strength.

It depends decisively on the quality of the chain and on the number of chain strands i.e. the plate combination of the leaf chains. This means that chains with the same tensile strength differ from one another by sometimes more than 100 % in their fatigue strength, and thereby in their real quality and suitability.

The influence of multiple-strands is so recognisable that chains with the same quality as single-strand chains i.e. leaf chains, the plate combination 2 x 2 displays a more than doubled fatigue strength than a 4-strand roller chain i.e. a leaf chain with plate combination 8 x 8.

The consequence of these facts has to be that individually suited safety factors have to be selected for chains with differing plate combinations and manufactured quality. Should this really be carried out appropriately, then safety factors from $S = 4$ up to $S = 20$ will come into play. Selection of the correct safety factor will in the end become a decisive safety risk.

Rexnord recommends the chain-specific fatigue strength values and you decide whether the safety-relevant stipulations are fulfilled with your choice of chain.

What is better:

Take advantage of the all-round experience of Rexnord for designing and constructing chain drives.

And please note:

Only the fatigue strength gives information about whether a chain is "long-lasting". The tensile strength is not suitable for safe dimensioning.

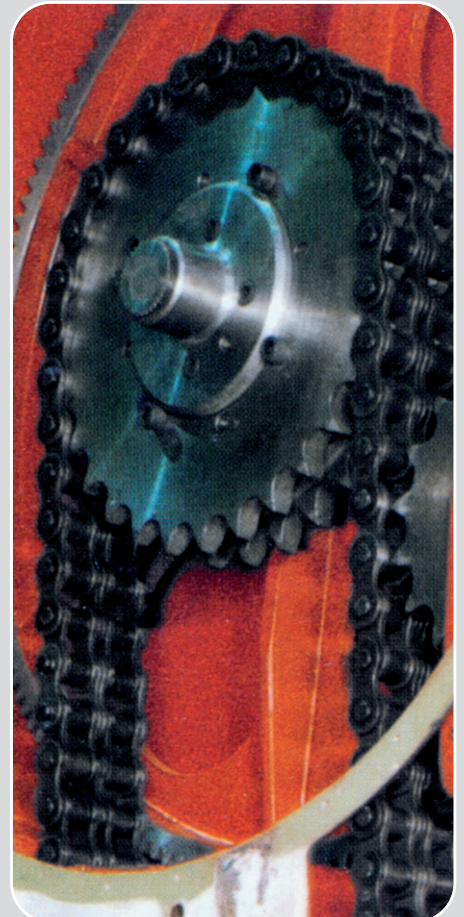

Recommendations for use

Lubrication

The lubrication of chains should be such that they are always covered over the entire surface with well-running oil, i.e. joint components and side plates have to be oily at all times.

Chain installation

All sprockets forming part of a chain drive have to be installed in such a way that correct alignment is ensured during the entire operation. Alignment can be considered to be sufficient if there are no cross-forces acting on the chain.

Sprocket shafts should be parallel as far as possible, the max. permitted deviation being ca. 3°. The chain is expected to run smoothly.

Chain tension

Each chain must have a certain amount of slack on the return run to ensure smooth and quiet running. This return strand should hang between ca. 2 - 3 % of the distance between axes or shafts. The chain drive arrangement can then be seen as effective when the drive strand is above and the return strand below.

Chain drives with reversing operation should not have any slack as this would cause a delay in the change of direction. The disadvantage with this application is that the sprockets should have at least 21 teeth to avoid unnecessary dynamic loads and excessive noise. If the shaft separation is more than 1 m then both strands have to be supported by guides(reverse operation only).

Attention: Slackness is measured on the upper hanging chain.

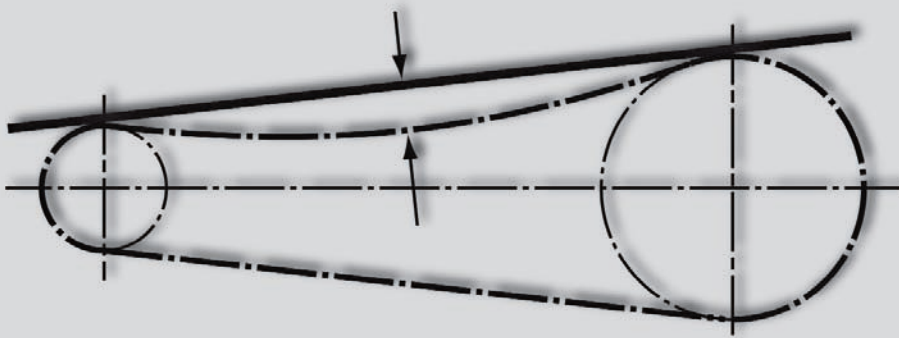

Permissible chain wear

Wear between pins and bushes on roller chains as well as between pins and plates on leaf chains causes chain elongation. This should be no more than 3 %. If this value is exceeded, then the chain has to be replaced (3 % = 30mm per metre). If sprockets are used with numbers of teeth of more than 67, then an earlier exchange is necessary according to the formula below.

Permissible chain stretch: $200/Z$ %.

Z= number of teeth on large sprocket.

Chains should always be exchanged if there are signs of visible damage. If chains are fixed at both ends, e.g. on fork-lift trucks, then they need to be measured only along the working area.

Excessive noise

Basically chain drives are less noisy than any comparable drive elements. If a chain drive does appear to be too noisy, then faulty design or maintenance is almost certainly the cause.

If such problems do occur, get in contact with Rexnord application consulting.

Chain pulsation

In certain operating conditions chain drives can develop pulsations in both drive and return strands. Such pulsations lead to premature wear and material fatigue as well as increased noise development. Here we have to differentiate between vertical and cross-pulsation in the strand. A satisfactory solution can be found by fitting guide-rails which adjust the drive chain slightly from the normal drive direction as well as a suitable number of teeth on the sprocket.

Hydrogen brittleness

If heat-treated materials are exposed to hydrogen (chemical name H) the material draws the hydrogen out of the environment.

This process leads to decomposition of the molecular structure of heat-treated steel.

All chains and roller bearings are affected by this phenomenon. Many chain users might have been surprised by side plates becoming brittle and breaking without deformation or any sign of overloading. If there is free hydrogen in the atmosphere, such breakages cannot be avoided. Free hydrogen can be produced by for example the following processes:

1. contact between metals and acids,
e.g. $H_2SO_4 + Fe = FeSO_4 + 2H$
2. electrolytic processes

It is therefore "rather" dangerous to use electrolytic processes with cadmium, chromium or tin on already finished chains. Rexnord solves such problems by special procedures during manufacture.

Chains with metallic surface protection

Should you require special corrosion protection through surface treatment, then get in contact with the specialists at Rexnord application consulting.

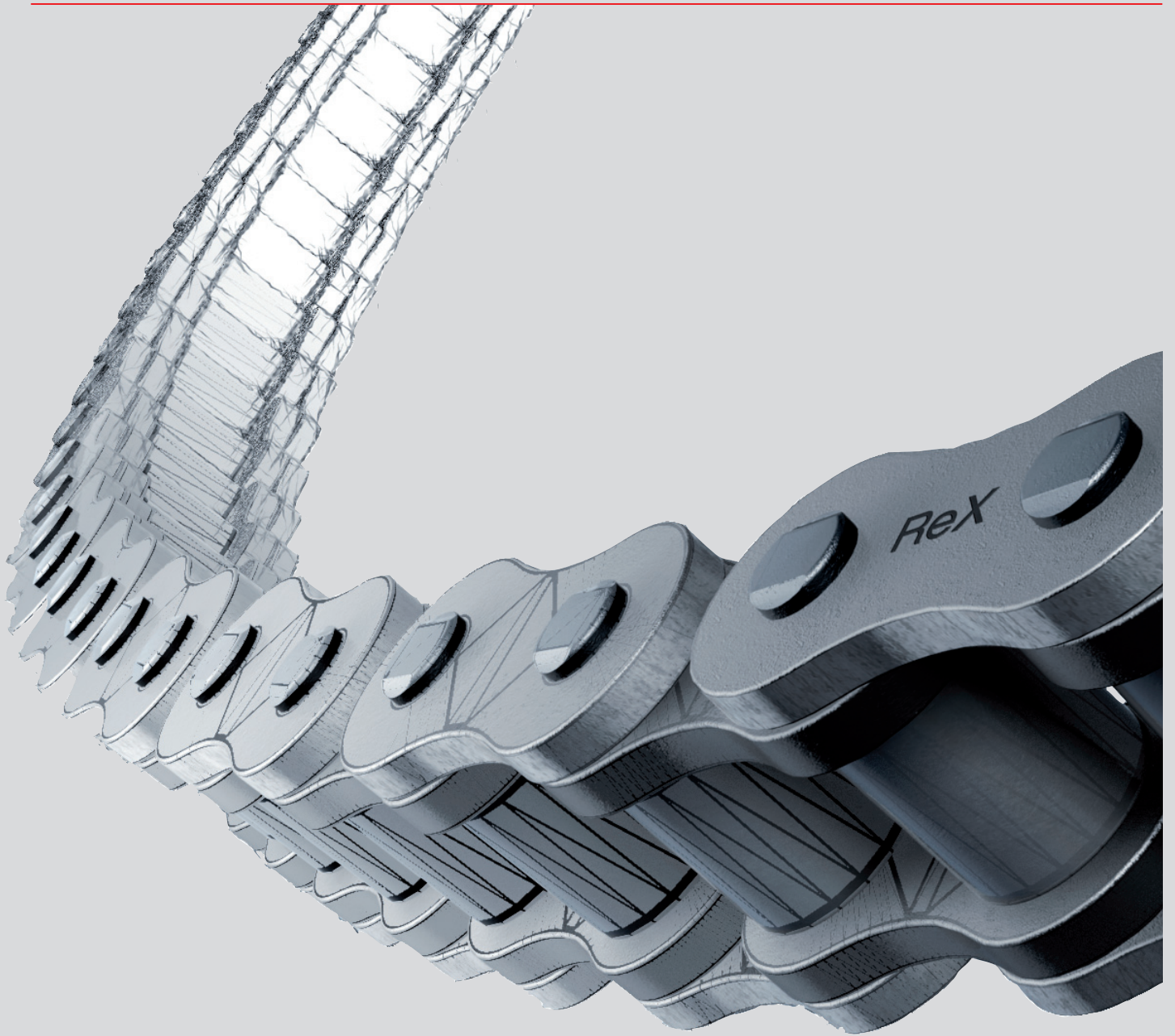

Chains and accessories in this catalogue do not constitute lifting accessories or safety components in terms of the EC machinery directive 98/37/EG and 2006/42/EG (new edition) and therefore should not be so designated.

Reprint and partial reproduction of this catalogue only with the express permission from Rexnord
Designs of products can be subject to changes/modifications, errors excepted.

Germany
Holland
Switzerland
Austria
Eastern Europe

Central
Rexnord Kette GmbH
 Industriestraße 1
D-57518 Betzdorf
 Phone: +49 2741 284-0
 Fax: +49 2741 284-250
 E-mail: rexinfo@rexnord.com

Rexnord Kette GmbH
Marketing office South-East
 Edelweißring 83
D-86343 Königsbrunn
 Phone: +49 8231 908-20
 Fax: +49 8231 908-21
 E-mail: oswald.wirth@rexnord.com

Rexnord Kette GmbH
Marketing office North-East
 Schwimmbadstr. 5
D-57648 Unnau
 Phone: +49 2661 916025
 Fax: +49 2661 916026
 Mobil: +49 171 4266308
 E-mail: guenter.krack@rexnord.com

Rexnord Kette GmbH
Marketing office North-West/NL
Marketing office South-West/CH
 Oberbergstraße 18
D-57520 Molzhain
 Phone: +49 2747 9130-88
 Fax: +49 2747 9130-90
 Mobil: +49 171 4435145
 E-mail: torsten.arend@rexnord.com

Austria & Eastern Europe
Rexnord Kette GmbH
 Tristangasse 36
A-9020 Klagenfurt
 Phone: +43 463 210-559
 Fax: +43 463 210-559
 Mobil: +43 664 4590708
 E-mail: hans.dengg@rexnord.com

Europe

Great Britain, Redditch
Rexnord Office 32
 Imex Spaces Business Park
 Oxleasow Road
 East Moons Moat
B98 ORE, United Kingdom
 Phone: +44 (1527) 830473
 Fax: +44 (1527) 830501
 E-mail: derek.mack@rexnord.com

Denmark, Holte
Rexnord Kette
 Skovlytoften 26
DK-2840 Holte
 Phone: +45 (45) 469702
 Fax: +45 (45) 469701
 E-mail: erik.nielsen@rexnord.dk

Finland, Kotka
Rexnord N.V. S/A
 Antintie
FI-48600 Kotka
 Mobil: +358 400 411-819
 E-mail: mika.antila@rexnord.com

France, Peronnas
Rexnord France Holding SAS
 Allée de la grange magnien
 Place de Neuhausen
F-01960 Peronnas
 Phone: +33 474 473-564
 Fax: +33 474 243-565
 Mobil: +33 675 567 091
 E-mail: allain.baheux@rexnord.com

Italy, Milano
Rexnord
 Via Cassanese, 224
 Centro Direzionale Milano Oltre
 Plazzo Tintoretto Piano 1
I-20090 Segrate (MI)
 Phone: +39-02-269-9271
 Fax: +39-02-269-92750
 E-mail: massimo.camisasca@rexnord.com

World

Australia, Picton
Rexnord Australia Pty. Ltd.
 25 Henry Street
Picton NSW 2571
 P.O. Box 620
 Phone +61-2-4677-3811
 Fax +61-2-4677-3812

Brazil, Sao Leopoldo
Rexnord Correntes Ltda.
 Rua Christopher Levalley, 187
93037-730 Sao Leopoldo - RS
 Phone +55-51-579-8022
 Fax +55-51-579-8029

Canada, Toronto
Rexnord Canada
 81 Maybrook Drive
Scarborough, Ontario M1V 3Z2
 Phone +1 416-297-6868
 Fax +1 416-297-6873

Singapore
Rexnord International, Inc.
 One Sims Lane
Singapore 387 355
 Phone +65-6338-5622
 Fax +65-6338-5422

Latin America, Miami
Rexnord International, Inc.
 7200 N.W. 19th Street
 Suit 202
Miami, Florida 33126
 Phone +1-305-592-4367
 Fax +1-305-592-5384

United States, Milwaukee
Rexnord Industries, Inc.
 4701 W. Greenfield Avenue
Milwaukee, WI 53214
 Phone +1-414-643-3000
 Fax +1-414-643-3078



Rexnord Kette GmbH
 Postfach 120
57501 Betzdorf / Germany
 Industriestraße 1
57518 Betzdorf / Germany
 Tel. +49 2741 284-0
 Fax +49 2741 274 / 289 / 362
 eMail: rexinfo@rexnord.com
 www.rexnord.eu